

M X - 8 0

EPSON DOT MATRIX PRINTER

TYPE II

Operation Manual

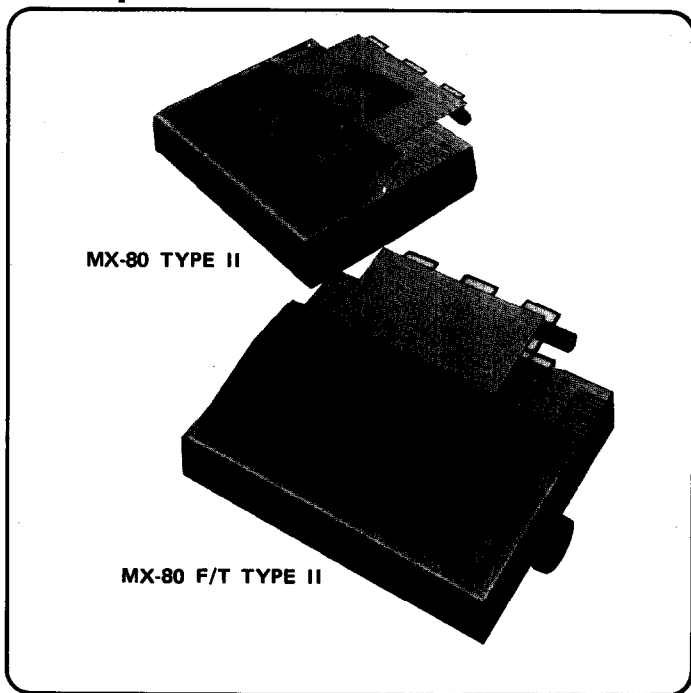

EPSON

P8190014-2

TABLE OF CONTENTS

GENERAL DESCRIPTION	1
1. Introduction	1
2. Characteristics	2
INSTALLATION OF MX-80 TYPE II	3
1. Unpacking	3
1.1. Unpacking steps	3
1.2. Repacking steps	3
2. Counting the Parts	3
3. Installation of the Printer	5
4. Cartridge Ribbon Setting	8
5. Separator Installation	10
6. Paper Loading	10
6.1. Loading of fanfold paper	10
6.2. Removal of fanfold paper	13
6.3. Column layout on fanfold paper	14
6.4. Top of form position setting	14
7. Gap Adjustment	15
8. Power Connection	15
INSTALLATION OF MX-80 F/T TYPE II	17
1. Unpacking	17
1.1. Unpacking steps	17
1.2. Repacking steps	17
2. Counting the Parts	17
3. Installation of the Printer	18
4. Cartridge Ribbon Setting	22
6. Separator Installation	23
6. Dismounting of Tractor Unit	24
7. Paper Loading	25
7.1. Fanfold paper	25
7.1.1. Loading of fanfold paper	25
7.1.2. Removal of fanfold paper	27
7.1.3. Column layout on fanfold paper	28
7.1.4. Top of form position setting	28
7.2. Roll paper	29
7.2.1. Roll paper holder	29
7.2.2. Loading of roll paper	29
7.3. Cut paper sheet	30
7.3.1. Loading of cut paper sheet	30
8. Gap Adjustment	34
9. Power Connection	34

OPERATION	36
1. Switches and Indicators	36
1.1. Switches	36
1.2. Indicators	37
1.3. Printer initial check	38
2. Buzzer	39
3. Paper End Detector	39
4. Self-Test	40
5. Setting of DIP Switches	41
5.1. Setting of DIP switch No. 1	45
5.2. Setting of DIP switch No. 2	46
5.3. Coding tables	47
5.4. Setting sequence of functional specifications	48
WHAT IS THE MX-80 TYPE II?	52
1. What Is a Dot Matrix Printer?	52
2. Definitions of Some Terms Often Used.	54
3. Control Codes in the Text Mode	56
3.1. Print action codes	57
3.2. Paper formatting codes	58
3.3. Character designation codes	63
3.4. Other codes	66
4. Control Codes in the Bit Image Mode.	67
4.1. Normal-density bit image mode setting by ESC K + n_1 + n_2	68
4.2. Dual-density bit image mode setting by ESC L + n_1 + n_2	70
4.3. Relationship between data and dot wires	71
4.4. How to obtain n_1 and n_2	72
4.5. Programming examples	73
MAINTENANCE	78
1. Preventive Maintenance	78
2. Parts Replacement	78
SPECIFICATIONS	80
APPENDIXES..	83
1. Construction of MX-80 Type II and MX-80 F/T Type II	83
2. Parallel Interface	87
3. ASCII Code Table	91
4. Character Fonts	92
5. Control Codes	96

LIST OF FIGURES

Fig. 1 EPSON MX-80 Type II and MX-80 F/T Type II Dot Matrix Printers ...	1
Fig. 2 Contents of Carton	4
Fig. 3 Laying Printer on Firm Surface	5
Fig. 4 Assembly Tools	6
Fig. 5 Removal of Shipping Screws	7
Fig. 6 Removal of Printer Lid	7
Fig. 7 Remounting of Printer Lid	8
Fig. 8 Cartridge Ribbon Setting	8
Fig. 9 Cartridge Ribbon Setting	9
Fig. 10 Examples of Correct and Incorrect Ribbon Setting	9
Fig. 11 Separator Installation	10
Fig. 12 Insertion of Fanfold Paper	11
Fig. 13 Raising of Sprocket Lock Levers	12
Fig. 14 Engagement of Paper Feed Holes on Feeding Pins	12
Fig. 15 Printer with Fanfold Paper Set Completely	13
Fig. 16 Example of Paper Arrangement	13
Fig. 17 Top of Form	14
Fig. 18 Gap Adjustment	16
Fig. 19 Contents of Carton	18
Fig. 20 Laying Printer on Firm Surface	19
Fig. 21 Assembly Tools	20
Fig. 22 Removal of Shipping Screws.	20
Fig. 23 Removal of Printer Lid	21
Fig. 24 Cartridge Ribbon Setting	22
Fig. 25 Cartridge Ribbon Setting	22
Fig. 26 Examples of Correct and Incorrect Ribbon Setting	23
Fig. 27 Separator Installation	2 3
Fig. 28 Dismounting of Tractor Unit	24
Fig. 29 Mounting of Tractor Unit	24
Fig. 30 Insertion of Fanfold Paper	25
Fig. 31 Raising of Sprocket Lock Levers	26
Fig. 32 Engagement of Paper Feed Holes on Feeding Pins	26
Fig. 33 Printer with Fanfold Paper Set Completely	27
Fig. 34 Example of Paper Arrangement	27
Fig. 35 Top of Form Position Setting.	28
Fig. 36 Loading of Roll Paper (1)	29
Fig. 37 Loading of Roll Paper (2).	30
Fig. 38 Loading of Roll Paper (3)	30
Fig. 39 Loading of Cut Paper Sheet	31
Fig. 40 Adjustment of Inserted Paper Position	31

Fig. 41 Alignment of Side Edges	32
Fig. 42 Form Position Setting Mark	32
Fig. 43 Print Area	32
Fig. 44 Setting of Cut Paper Sheet	33
Fig. 45 Printer with Cut Paper Sheet Set Completely	33
Fig. 46 Gap Adjustment	35
Fig. 47 Switches and Indicators on Control Panel	36
Fig. 48 Printer Initial Check	38
Fig. 49 Flowchart of Paper Out Status Release Procedure.	39
Fig. 50 Removing Manual Paper Feed Knob.	41
Fig. 51 Loosening All 4 Screws	41
Fig. 52 Pulling Out Wires Hooked to Control Panel.	42
Fig. 53 Construction of Type II Printer	43
Fig. 54 Location of DIP Switches	44
Fig. 55 Setting DIP Switches	44
Fig. 56 Setting Amount of Line Spacing	48
Fig. 57 Setting Form Length per Page	49
Fig. 58 Setting Number of Columns per Line.	50
Fig. 59 Setting Skip-over Perforation Function	51
Fig. 60 Dot Wire.	53
Fig. 61 Formation of Character "E"	53
Fig. 62 Line Spacing.	54
Fig. 63 Relationship between Data and Dot Wires	71
Fig. 64 Data Transfer Sequence in Bit Image Mode	72
Fig. 65 Example of Graphic Pattern Formation	73
Fig. 66 Normal-Density and Dual-Density Modes	75
Fig. 67 Examples of Bit Image Printing	76
Fig. 68 Example of Expression of Brightness	77
Fig. 69 Replacement of Print Head	79
Fig. A1-1 Control Circuit Diagram	84
Fig. A1-2 Driver Circuit Diagram	85
Fig. A2-1 Parallel Interface Timing	89

LIST OF TABLES

Table 1 Interface Signals in Paper-Out Status.....	39
Table 2 Functions and Conditions of DIP Switch No. 1.....	45
Table 3 Character Size and Maximum Column Length.....	46
Table 4 Functions and Conditions of DIP Switch No. 2.....	46
Table 5 International Character Set Designation.....	47
Table 6 International Character Sets.....	47
Table A2-1 Connector Pin Assignment and Descriptions of Interface Signals	8 7
Table A2-2 Relations among ON-LINE, SLCT IN, DC1/DC3 and Interface Signal	8 9

GENERAL DESCRIPTION

1. Introduction

Ideal for computer business applications, the MX-80 Type II Dot Matrix Printer is the latest extension of EPSON advanced printer technology. This new printer couples innovative design and precision manufacturing with long life, low cost, light weight and superior performance. The MX-80 Type II features a 9 x 9 dot matrix print head that can be replaced easily, and 80 CPS bidirectional printing with logic seeking capability. This printer also offers 40-, 66-, 80-, and 132-column printing widths. And characters can be printed in any desired size - normal, enlarged, condensed, etc. Another important feature of the MX-80 Type II is its capability of printing not only in both Text and Bit Image* modes but also in mixed Text/Bit Image Mode.

A one-chip microcomputer performs all system control and the two built-in stepper motors of the printer control the carriage movement and paper feeding functions respectively. Therefore, versatile software controls, such as form feed, programmable line spacing and skip-over perforation are at your disposal. In addition, various interface options are available to permit handshaking with most VSBC computers.

In addition to the MX-80 Type II which is an adjustable sprocket pin feed type, a friction and adjustable sprocket feed type called "MX-80 F/T Type II" is also available. In this manual, installation of MX-80 Type II and MX-80 F/T Type II will be described individually and then the operation which is common to both will be described.

*Bit Image printing refers to the hard-copy production of illustrations, graphs, charts, etc., on the Printer by activating 8 dot wires respectively under software control.

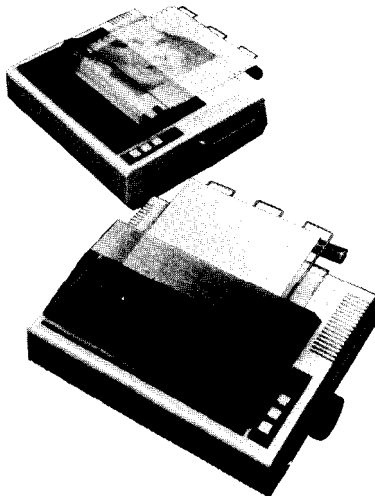

Fig. 1 EPSON MX-80 Type II and MX-80 F/T Type II Dot Matrix Printers

2. Characteristics

The MX-80 Type II and MX-80 F/T Type II have been designed as a printer with versatile functions to meet a wide range of applications from small business to home uses and even for hobbies. The following is a brief summary of their major characteristics.

- (1) Both text printing for general data processing and Bit Image printing for graphic data processing are freely available.
In the Bit Image printing, both normal density (480 dots/line in horizontal direction) and dual density (960 dots/line in horizontal direction) modes are selectable under software control.
- (2) Wide variation of printing width and character size
 - (a) 40 characters/line (enlarged character)
 - (b) 66 characters/line (enlarged-condensed character)
 - (c) 80 characters/line (normal character)
 - (d) 132 characters/line (condensed character)
 - (e) Programmable column length
- (3) Versatile functions to meet various business applications
 - (a) Top of Form - page length setting in line or inch units is possible, with initial setting to 11 or 12 inches.
 - (b) Skip-over perforation - automatic skip-over function selectable by DIP switch setting or variable by software.
 - (c) Programmable line spacing.
 - (d) Vertical tabulation and horizontal tabulation
 - (e) Buzzer, printer select/deselect function.
- (4) High throughput by bidirectional printing with logic seeking capability.
- (5) Easy-to-replace "throwaway" print head. The print head has a life expectancy of approx. 100 x 10⁶ characters.
- (6) 8 international character sets are selectable by DIP switch setting or software.
- (7) Complete with standard equipment including paper end detector, custom cartridge ribbon, etc.

INSTALLATION OF MX-80 TYPE II

1. Unpacking

Before removing the MX-80 Type I I from the carton, check the box for evidence of shipping damage or mishandling. If such evidence is present, notify the carrier immediately.

1.1. Unpacking steps

Unpacking steps are as follows:

STEP 1. Open the carton.

STEP 2. Remove accessories.

STEP 3. Remove the MX-80 Type I I holding its underside and lifting it straight up with the packing material attached.

STEP 4. Place the Printer with the packing material on a table or any other convenient flat surface.

STEP 5. Take off the packing material carefully.

STEP 6. Remove the vinyl cover.

1.2. Repacking steps

Repacking can be carried out by following the above steps in the reverse order. (Repacking: Shipment for repair, storage, etc.)

NOTE: It is recommended that all original packing materials be saved for reuse in case the MX-80 Type II requires reshipment in the future.

2. Counting the Parts

The MX-80 Type II and standard accessories are as shown in Fig. 2. Upon unpacking, if you notice any listed contents missing or evident damage, contact the store where you purchased the MX-80 Type I I as soon as possible.

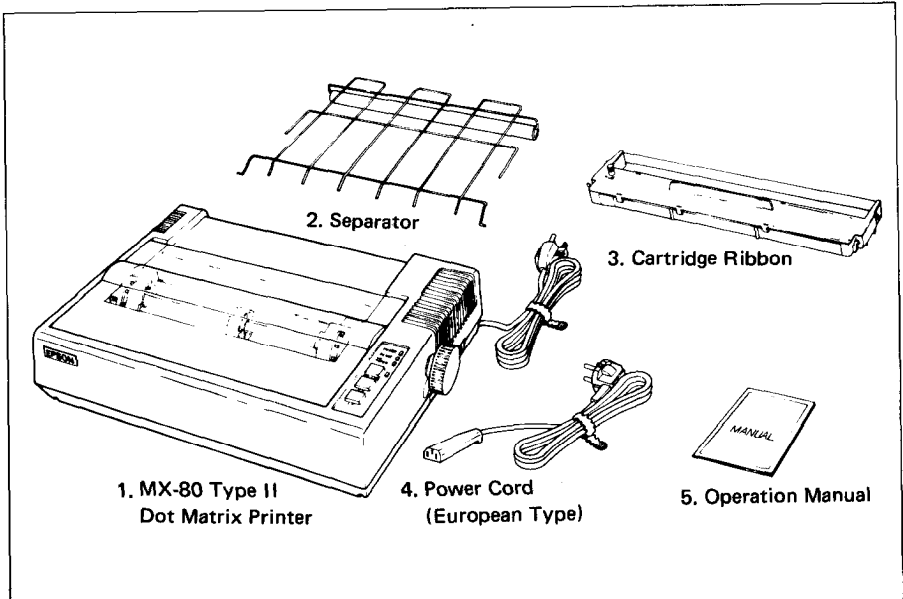

1. MX-80 Type II Dot Matrix Printer	1
2. Separator	1
3. Cartridge Ribbon	1
4. Power Cord (Only European Type 220/240V)	1
5. MX-80 Type II Operation Manual	1

Fig. 2 Contents of Carton

3. Installation of the Printer

(1) Operating site selection

When installing the MX-80 Type I I, observe the following instructions.

- (a) Place the Printer on a bench, tabletop or any other convenient flat surface with enough room for the separator in the back of the Printer. Your layout may look like Fig. 3.

NOTE: Rubber feet are provided to prevent the marring of the surface on which the MX-80 Type I I is placed.

- (b) Avoid operating the MX-80 Type I I in places where it may be exposed to direct sunlight or where a great deal of greasy dust exists in the air.

NOTE: Greasy dust may cause the malfunction of the print head.

- (c) Connect the power cord to an outlet separated from those connected to electric noise-generating equipment, such as large-power motors, refrigerators, etc.
- (d) Do not subject the Printer to temperatures below 5°C (40°F) or above 35°C (95°F) during operation, to sudden changes in temperature, or to extreme shock.
- (e) Avoid use of the Printer in humid locations or in the vicinity of heat generating sources such as heater, etc.

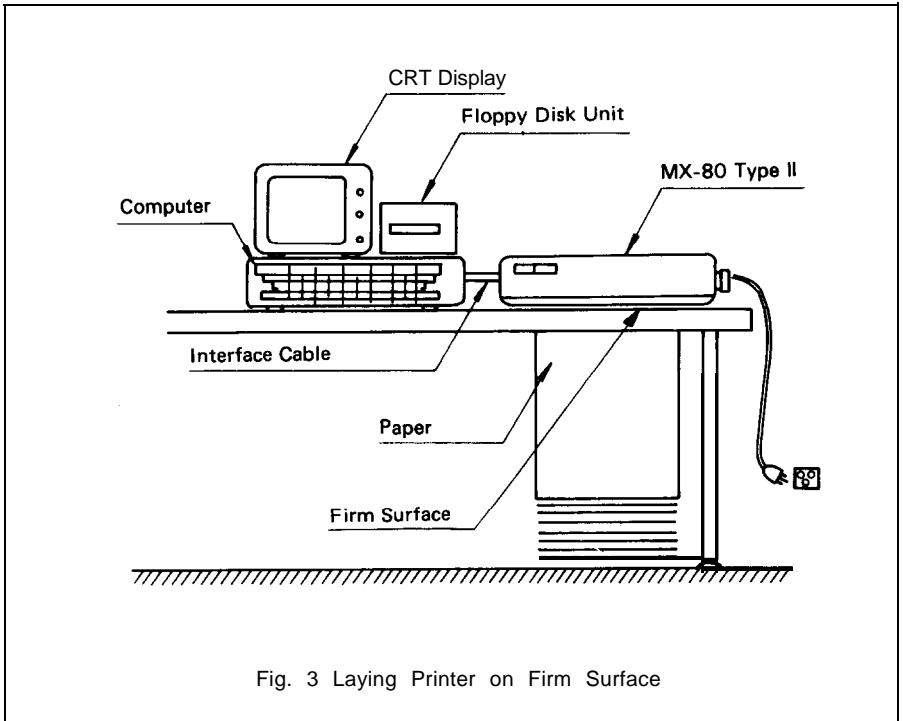

Fig. 3 Laying Printer on Firm Surface

(2) Removal of protective paper for paper end detector

The MX-80 Type II is provided with a protective paper inserted between the inner and outer paper guides to protect the paper end detector from damage due to shocks or vibrations during transportation. Before using the Printer, be sure to remove this paper. If the MX-80 Type II is to be reshipped, remember to return it to the original position.

(3) Prepare tools

Prepare the following two tools to disassemble or assemble the printer.

- (1) Phillips type screwdriver 1 pc.
- (2) Round-blade type screwdriver 1 pc.

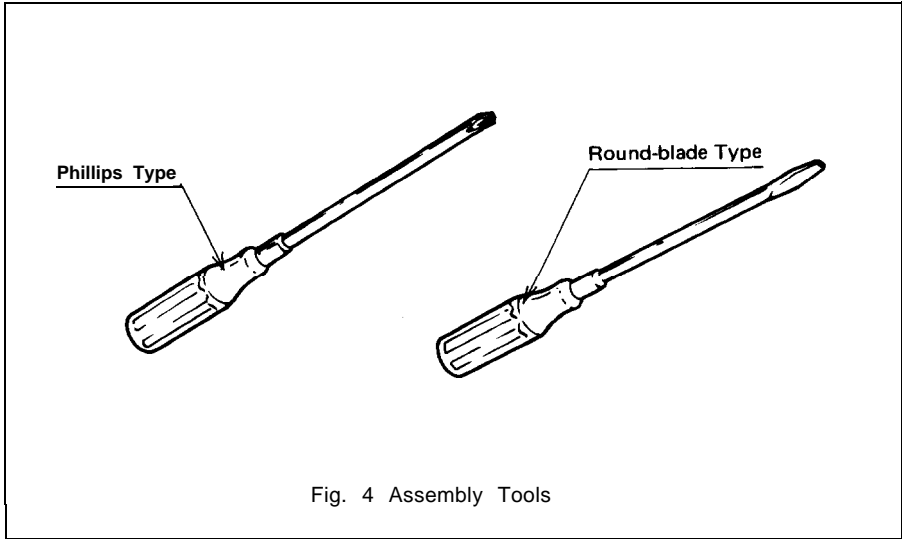

Fig. 4 Assembly Tools

(4) Removal of shipping screws

The purpose of the shipping screws is to protect the MX-80 Type II against any damage that may be caused by shocks or vibrations during transportation. Therefore, before operating the MX-80 Type I I, remove the screws as described below. (See Fig. 5.)

STEP 1. Stand the printer on its left side.

STEP 2. Remove with a screwdriver, the two shipping screws visible on the underside of the lower case.

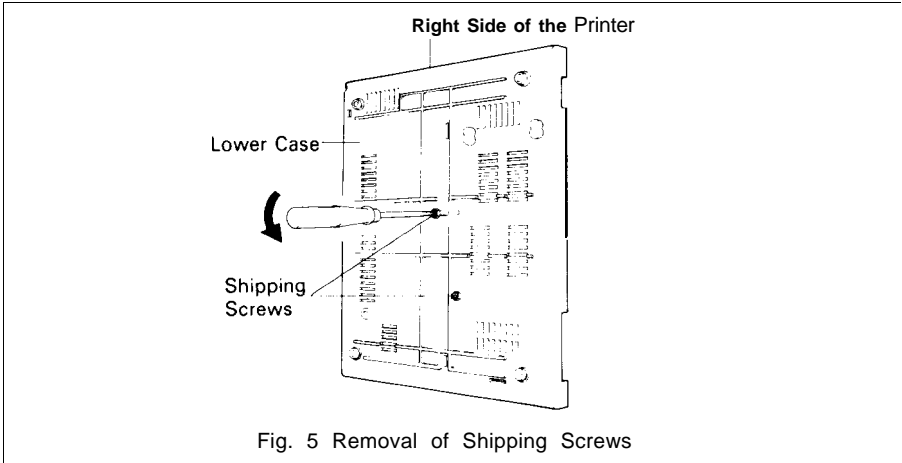

NOTE: Save the two shipping screws for possible future use.

< SUPPLEMENT >

- If the printer lid is an obstacle when removing the shipping screws, be sure to take off the printer lid by observing the following steps. Rough or careless handling of the printer lid may result in damage to, or even breakage of, its hinges.

STEP 1. Stand the printer lid upright.

STEP 2. Push the printer lid toward the right and pull up its left side. (See Fig. 6.)

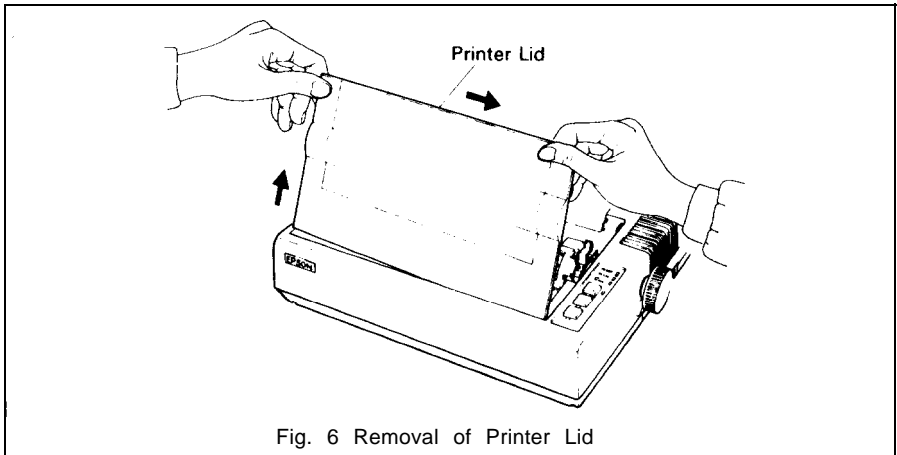

- When remounting the printer lid, be sure to observe the following steps:
STEP 1. Fit the right side of the printer lid onto the projection located at the right corner of the Printer's upper case. (See Fig. 7.)
STEP 2. Fit the left side of the printer lid onto the left projection and push the printer lid down,

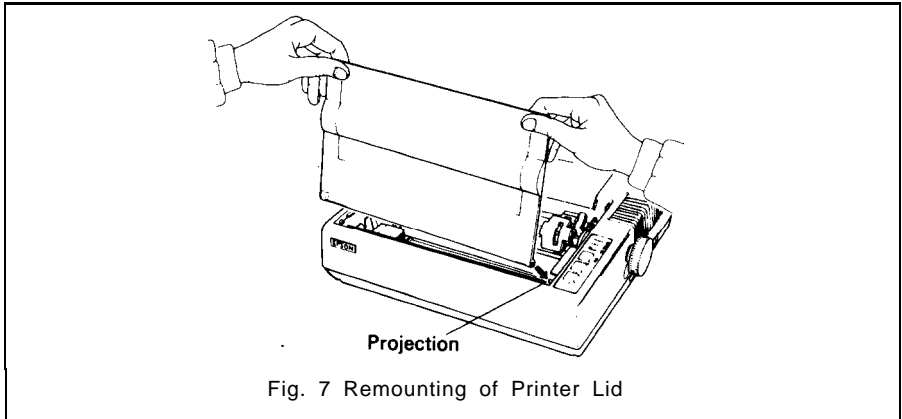

Fig. 7 Remounting of Printer Lid

4. Cartridge Ribbon Setting

EPSON's Cartridge Ribbon is compact, long-lasting, and very easy to set and remove. Furthermore, you have no need to soil your fingers in handling it.

- STEP 1. Open the printer lid (or remove it).
- STEP 2. Confirm that the scale (paper retainer) is turned toward the platen and is touching.
- STEP 3. Push the cartridge ribbon down and set it on the printer mechanism. To facilitate the cartridge ribbon setting, be sure to hold the projection at the center of the cartridge case when pushing the cartridge ribbon down. (See Fig. 8.)

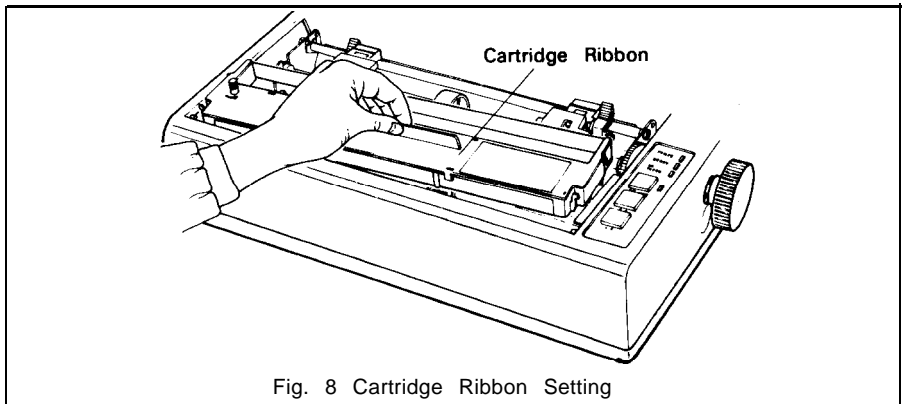

Fig. 8 Cartridge Ribbon Setting

STEP 4. Put the ribbon between the head nose and the ribbon mask. In this case, the ribbon can be set easily by hooking it to the edge of the head nose and turning the ribbon feeding knob of the cartridge case in the direction of the arrow (i.e., counterclockwise) while depressing the ribbon with a ball-point pen. Then, tension the ribbon by turning the ribbon feeding knob counterclockwise. (See Fig. 9.)

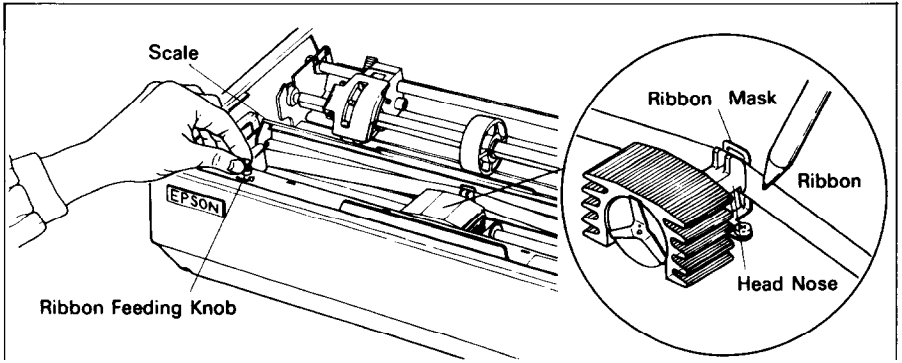

Fig. 9 Cartridge Ribbon Setting

- NOTES:**
1. Incorrect setting of the ribbon may cause it to come off. (See Fig. 10.)
 2. Confirm that the ribbon is neither twisted nor creased and that the cartridge is set properly

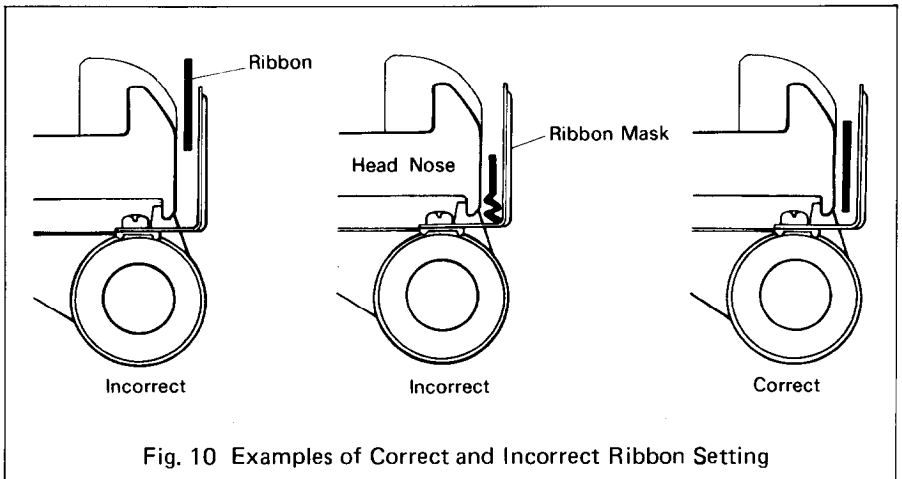

Fig. 10 Examples of Correct and Incorrect Ribbon Setting

5. Separator Installation

The separator of the Printer contributes to smooth paper feeding. Set the separator by inserting its edge into the two holes located at the rear part of the frame of the printer mechanism. (See Fig. 11.)

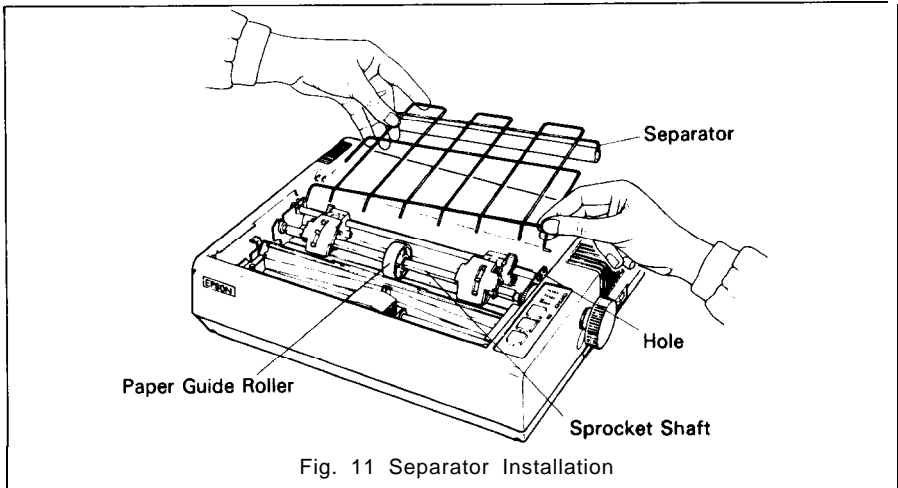

Fig. 11 Separator Installation

6. Paper Loading

6.1. Loading of fanfold paper

The MX-80 Type II Printer accommodates fanfold paper from 4" to 10" in width. To load the fanfold paper, observe the following procedure.

- STEP 1. Raise the printer lid.
- STEP 2. Turn the scale toward the front of the Printer and detach it from the platen.
- STEP 3. Confirm that the paper guide roller is at the center of the sprocket shaft. If not, set it at the center of the shaft.

NOTE: The paper guide roller contributes to smooth paper feeding.

- STEP 4. Raise the two paper holding covers, and be sure to insert the fanfold paper between the frame and plastic roller of the separator. (See Fig. 12.)

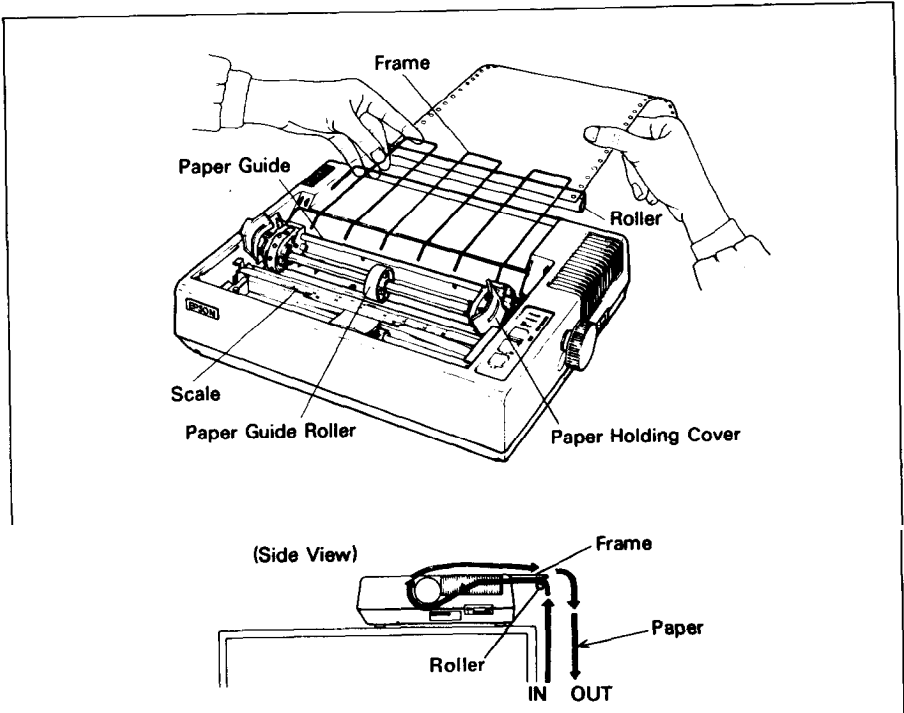

Fig. 12 Insertion of Fanfold Paper

- STEP 5. Push the paper into the insertion slot between the paper guides at the rear part of the printer mechanism.
- NOTE:** Be sure to pass the paper beneath the upper paper guide.
- STEP 6. After the leading edge of the paper has emerged from the Printer, pull it out gently to some length.

STEP 7. Raise the two sprocket lock levers to loosen, and adjust the sprocket pin position to the paper width. (See Fig. 13.)

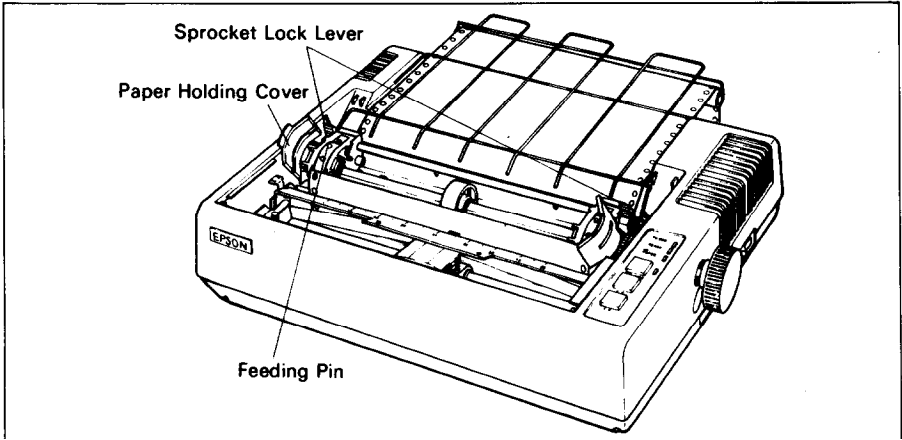

Fig. 13 Raising of Sprocket Lock Levers

STEP 8. Engage the paper feed holes of the paper on the feeding pins, push the scale back into position, and adjust the tension of the paper. Then push the paper holding covers and the two sprocket lock levers down. (See Fig. 14.)

NOTE: In this case, confirm that the feeding pins are centered in the respective paper feed holes of the paper.

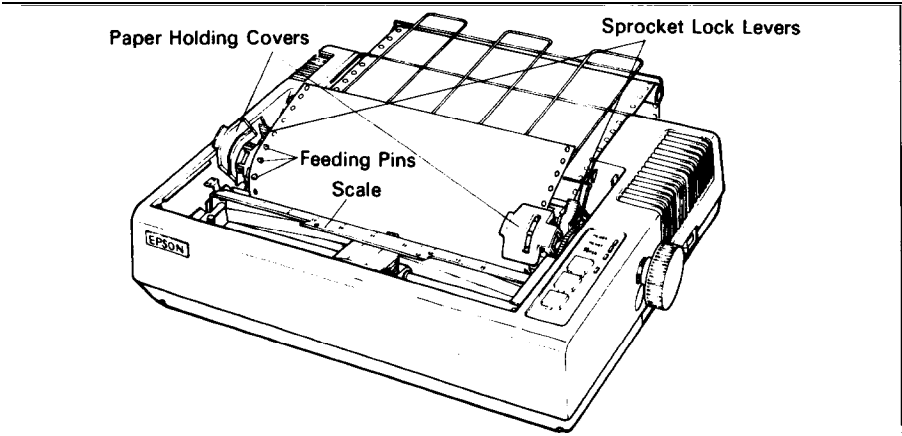
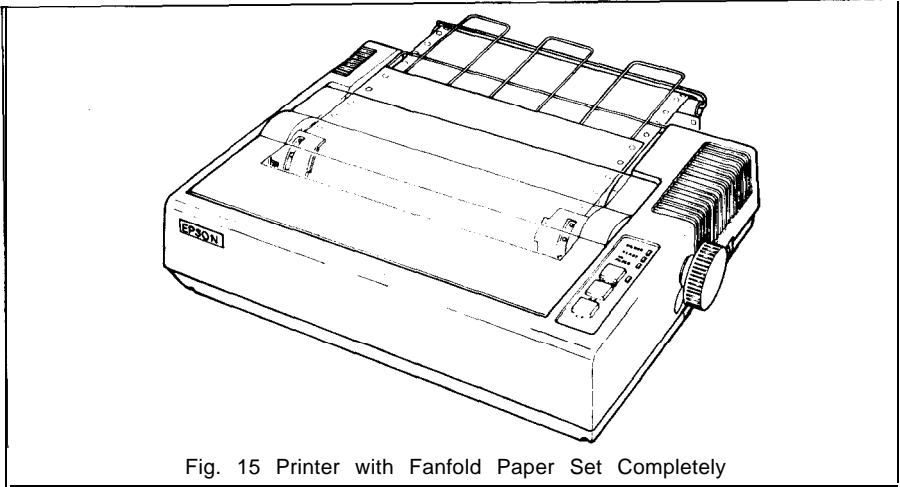
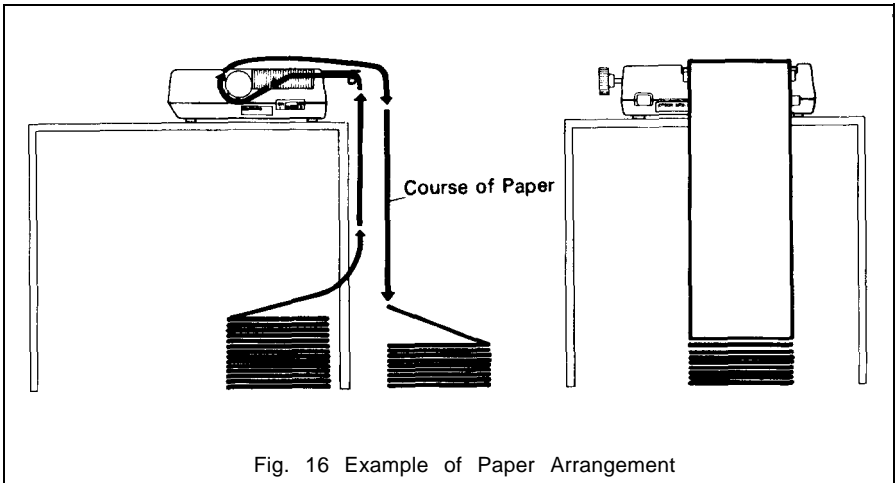

Fig. 14 Engagement of Paper Feed Holes on Feeding Pins

STEP 9. Put the printer lid on the Printer.



NOTE: When the MX-80 Type II is to be used on a desk or a bench, arrangement of the fanfold paper in parallel with the MX-80 Type II as shown below will permit the paper to be folded in an accordion style.



6.2. Removal of fanfold paper

To remove the fanfold paper, follow either of the two methods described below.

- (1) To disengage the paper from the paper holding mechanism, pull it forward out of the Printer.

NOTE: Do not attempt to pull out the paper in the backward direction.

- (2) Feed the paper out of the printer by electrical operation. For this, turn the Power Switch on and push the Line Feed button. (Details are described later.)

6.3. Column layout on fanfold paper

When fanfold paper of from 4" to 10" in width is supplied with the MX-80 Type I I, the graduations on the scale can be used as the indexes of print column positions (1 to 80). Alignment of the print start position on fanfold paper with the 1st column position at the extreme left of the scale will facilitate column layout. Accordingly, center the paper by adjusting it to these indexes of the scale.

6.4. Top of form position setting

The term "Top of Form position" is defined as the position in which the first print line lies on the form, and this position is determined when the power switch is turned on. Namely, adjust the paper position by the manual paper feed knob so that the required line position (i.e., the point at which the first line of the form is desired to be printed) is at the print head level. If, at this point, power is applied to the printer, this line position automatically becomes the Top of Form position.

When printing forms, the matchmarks located on both the sprockets facilitate the setting of the Top of Form position on the fanfold paper. To set the Top of Form position, first enter (or preprint) a mark at a position on the edge of the paper 77mm above the first print line position of the paper, then align this mark with the matchmarks on the sprockets by turning the manual paper feed knob. At this point, turn the Power Switch on and the Printer will recognize this position as the Top of Form position. Now, the printing can be started from the Top of Form position. In case of feeding one page of fanfold paper by operating the MX-80 Type II by the input of FF code, the abovementioned adjustment is effective.

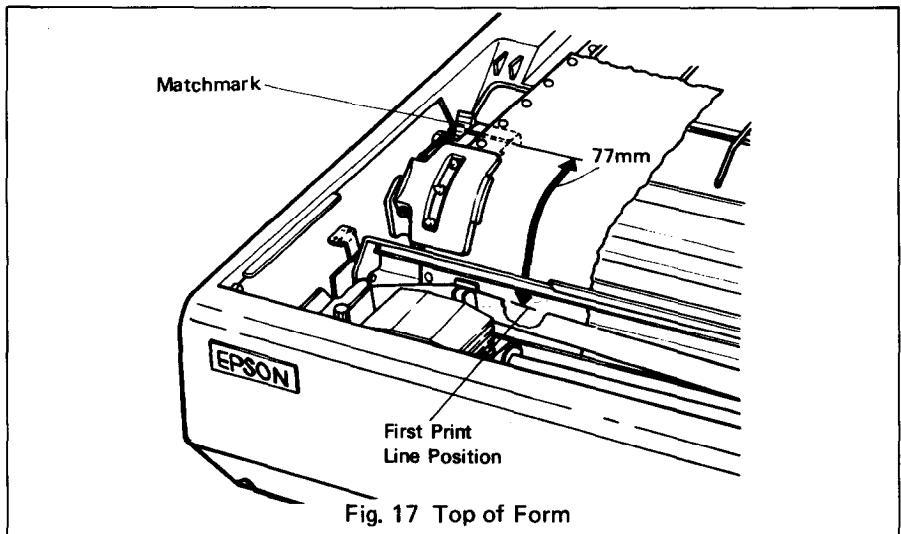

7. Gap Adjustment

The adjustment of a gap between the head nose and the platen is used to adjust the printing pressure as well as to suit paper of a different thickness.

- (1) Move the head adjusting lever (located on the left frame of the Printer) forward or backward to adjust the gap between the head nose and the platen. (See Fig. 18.)

Forward: To widen gap.

Backward: To narrow gap.

NOTE: With a thick paper, be sure to widen this gap.

- (2) Adjust the position of the head adjusting lever according to the type of paper to be used.

Paper	Position of adjusting lever
Single-leaf paper	Set the lever to the 4th step.
Carbon paper sheets	Set the lever to the 7th step.

- (3) Should printed characters become faint due to the use of the printer for an extended period, move the head adjusting lever backward (in the  direction) by one step. (See Fig. 18.)
- (4) When a set of carbon paper sheets is used, be sure that no characters are printed within the area two lines each above and below the perforation.

8. Power Connection

The EPSON MX-80 Type II Dot Matrix Printer is capable of operating on the following three types of AC power.

- (1) 115V AC, 60Hz
- (2) 220V AC, 50Hz
- (3) 240V AC, 50Hz

Before connecting the MX-80 Type II to a power source, make certain of the primary AC rating from the label located on the chassis at the rear of the Printer. After connection of the Printer to the proper power source and upon application of power to the Printer, "Initialization" will take place in the Printer with the effects described in paragraph 1.4, Appendix 1. If your MX-80 Type II has a primary AC rating different from the available power source, do not attempt to operate the Printer. Please obtain a replacement unit with the correct AC rating from the store where you purchased the MX-80 Type I I.

Head Adjusting Lever

⊖ Backward

⊕ Forward

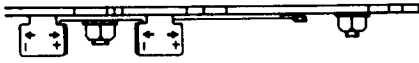
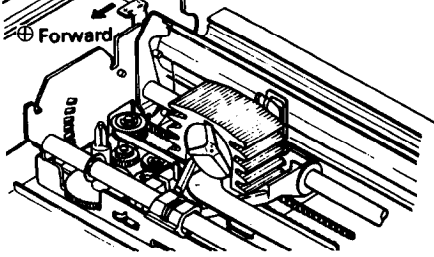

⊖ Backward ← → Forward ⊕

Head Adjusting Lever

4th step

(Side View)

7th step

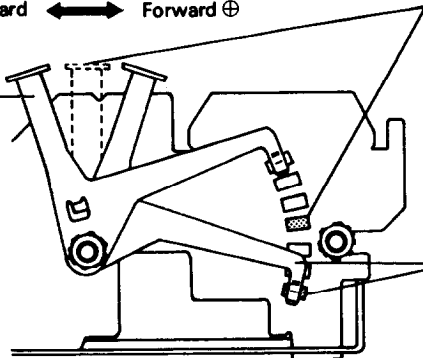

Fig. 18 Gap Adjustment

INSTALLATION OF MX-80 F/T TYPE II

1. Unpacking

Before removing the MX-80 F/T Type II from the carton, check the box for evidence of shipping damage or mishandling. If such evidence is present, notify the carrier immediately.

1.1. Unpacking steps

Unpacking steps are as follows:

STEP 1. Open the carton.

STEP 2. Remove accessories.

STEP 3. Remove the MX-80 F/T Type II by holding its underside and lifting it straight up with the packing material attached.

STEP 4. Place the Printer with the packing material on a table or any other convenient flat surface.

STEP 5. Take off the packing material carefully.

STEP 6. Remove the vinyl cover.

1.2. Repacking steps

Repacking can be carried out by following the above steps in the reverse order.

(Repacking: Shipment for repair, storage, etc.)

NOTE: It is recommended that all original packing materials be saved for reuse in case the MX-80 F/T Type II requires reshipment in the future.

2. Counting the Parts

The MX-80 F/T Type II and standard accessories are as shown in Fig. 19. Upon unpacking, if you notice any listed contents missing or evident damage, contact the store where you purchased the MX-80 F/T Type II as soon as possible.

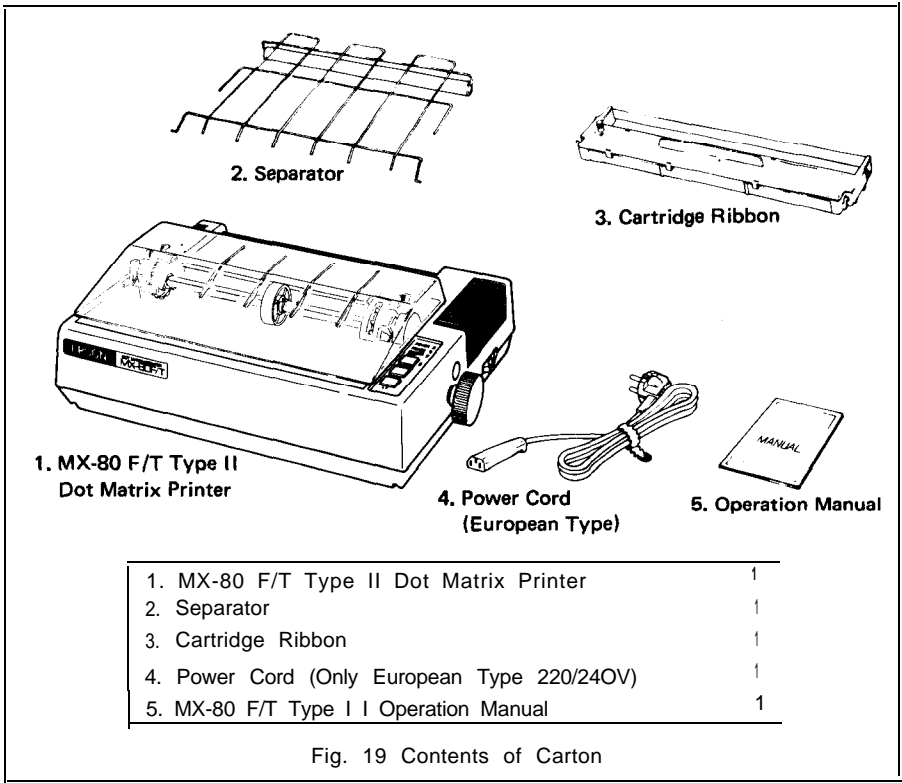

3. Installation of the Printer

(1) Operating site selection

When installing the MX-80 F/T Type I I, observe the following instructions.

- (a) Place the Printer on a bench, tabletop or any other convenient flat surface with enough room for the separator in the back of the Printer. Your layout may look like Fig. 20.

NOTE: Rubber feet are provided to prevent the marring of the surface on which the MX-80 F/T Type I I is placed.

- (b) Avoid operating the MX-80 F/T Type. I I in places where it may be exposed to direct sunlight or where a great deal of greasy dust exists in the air.

NOTE: Greasy dust may cause the malfunction of the print head.

- (c) Connect the power cord to an outlet separated from those connected to electric noise-generating equipment, such as large-power motors, refrigerators, etc.
- (d) Do not subject the Printer to temperatures below 5°C (40°F) or above 35°C (95°F) during operation, to sudden changes in temperature, or to extreme shock.

- (e) Avoid use of the Printer in humid locations or in the vicinity of heat generating sources such as heater, etc.

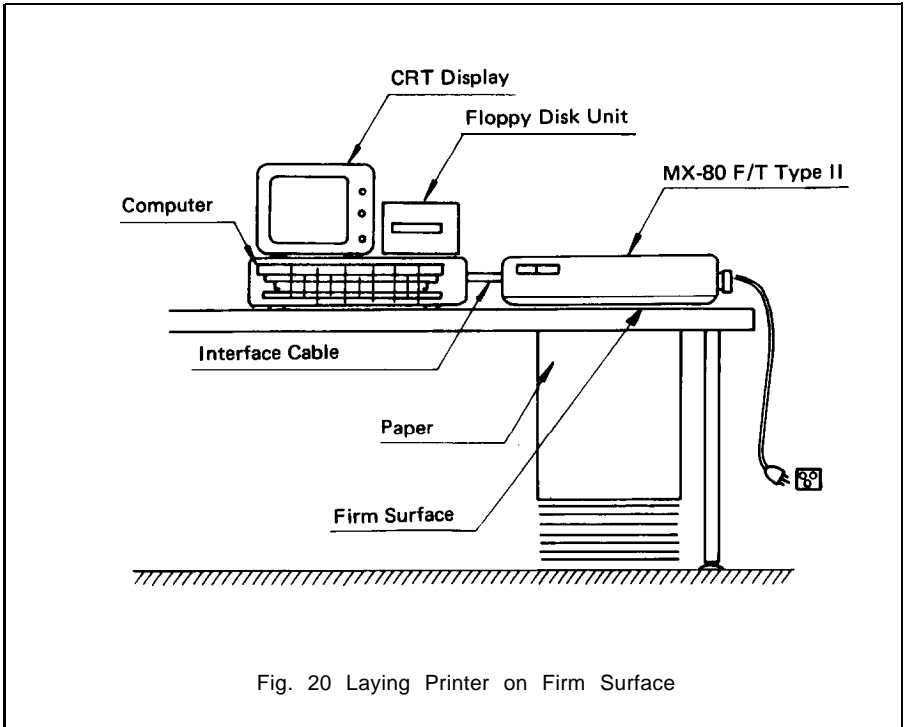

Fig. 20 Laying Printer on Firm Surface

(2) Removal of protective paper for paper end detector

The MX-80 F/T Type II is provided with a protective paper inserted between the inner and outer paper guides to protect the paper end detector from damage due to shocks or vibrations during transportation. Before using the Printer, be sure to remove this paper. If the MX-80 F/T Type II is to be reshipped, remember to return it to the original position.

(3) Prepare tools

Prepare the following two tools to disassemble or assemble the printer.

- | | |
|----------------------------------|-------|
| (1) Phillips type screwdriver | 1 pc. |
| (2) Round-blade type screwdriver | 1 pc. |

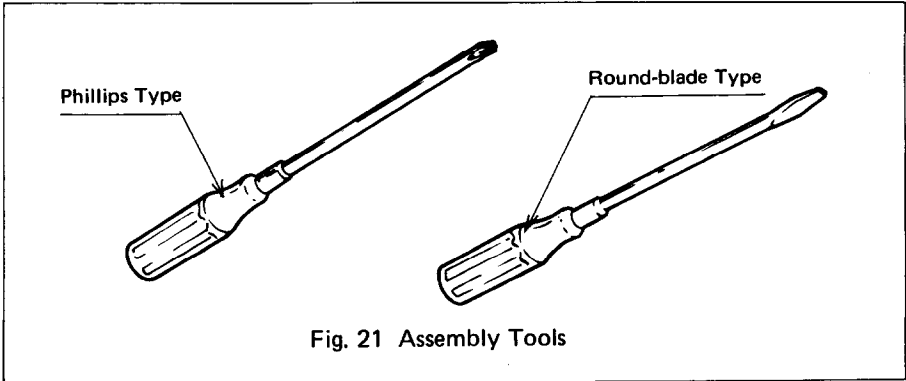

Fig. 21 Assembly Tools

(4) Removal of shipping screws

The purpose of the shipping screws is to protect the MX-80 F/T Type II against any damage that may be caused by shocks or vibrations during transportation. Therefore, before operating the MX-80 F/T Type II, remove the screws as described below. (See Fig. 22.1

STEP 1. Stand the printer on its left side.

STEP 2. Remove with a screwdriver, the two shipping screws visible on the underside of the lower case.

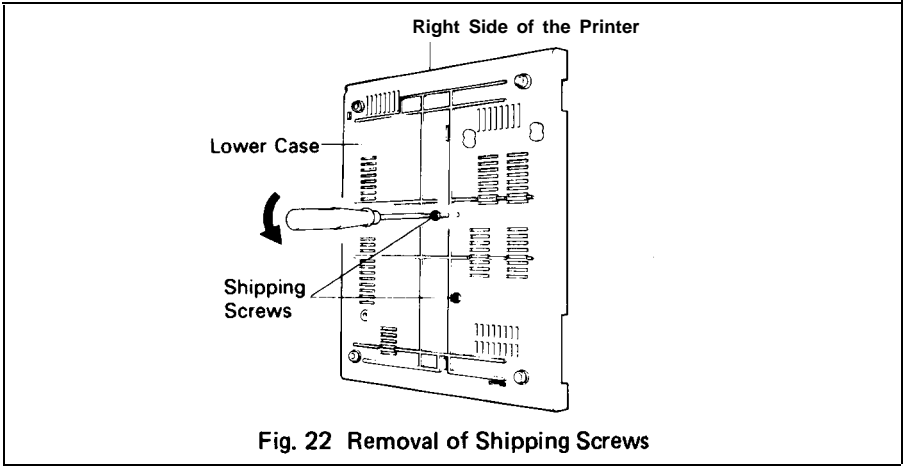

Fig. 22 Removal of Shipping Screws

NOTE: Save the two shipping screws for possible future use.

< SUPPLEMENT >

• If the printer lid is an obstacle when removing the shipping screws, be sure to take off the printer lid by observing the following steps. Rough or careless handling of the printer lid may result in damage to, or even breakage of, its hinges.

STEP 1. Stand the printer lid upright.

STEP 2. Push the printer lid toward the right and pull up its left side. (See Figs 23 (1) and (2).)

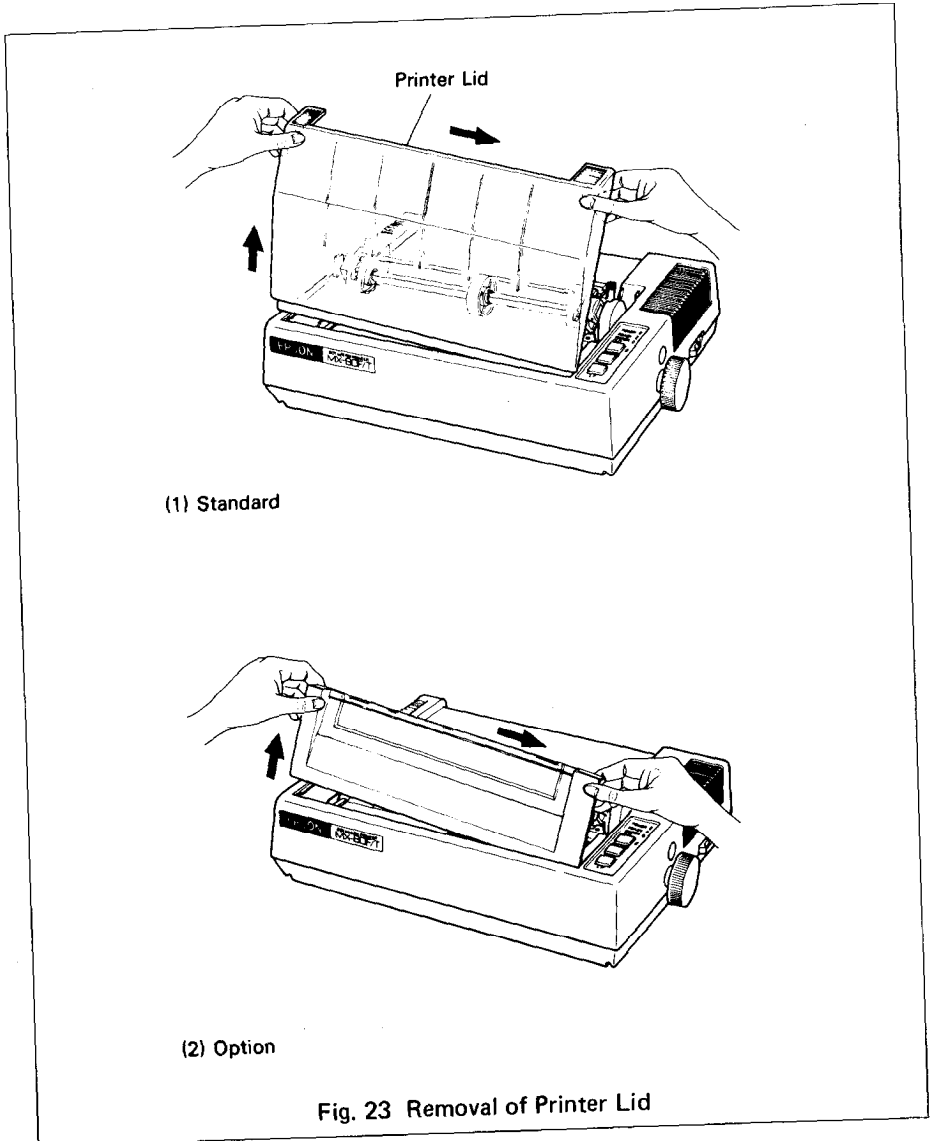

Fig. 23 Removal of Printer Lid

NOTE: The printer lid shown in Fig. 23 (2) is an Optional accessory.

4. Cartridge Ribbon Setting

EPSON's Cartridge Ribbon is compact, long-lasting, and very easy to set and remove. Furthermore, you have no need to soil your fingers in handling it.

STEP 1. Open the printer lid (or remove it).

STEP 2. Confirm that the scale (paper retainer) is turned toward the platen and is touching.

STEP 3. Push the cartridge ribbon down and set it on the printer mechanism. To facilitate the cartridge ribbon setting, be sure to hold the projection at the center of the cartridge case when pushing the cartridge ribbon down. (See Fig. 24.)

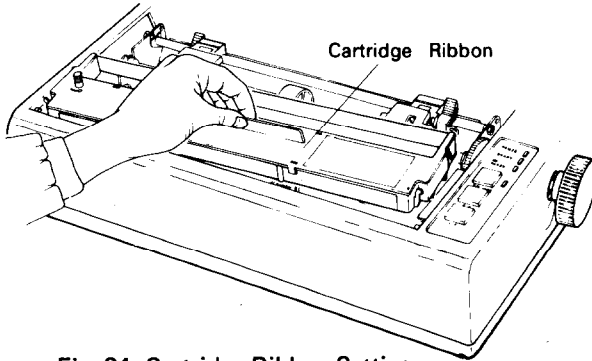

Fig. 24 Cartridge Ribbon Setting

STEP 4. Put the ribbon between the head nose and the ribbon mask. In this case, the ribbon can be set easily by hooking it to the edge of the head nose and turning the ribbon feeding knob of the cartridge case in the direction of the arrow (i.e., counterclockwise) while depressing the ribbon with a ball-point pen. Then, tension the ribbon by turning the ribbon feeding knob counterclockwise. (See Fig. 25.)

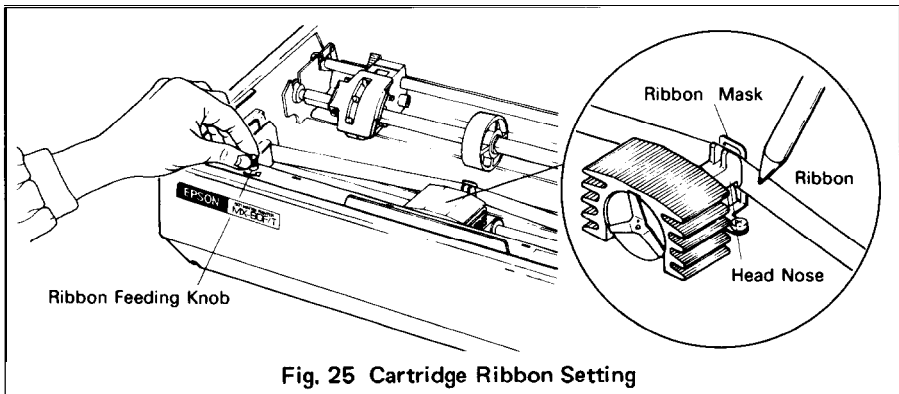

Fig. 25 Cartridge Ribbon Setting

- NOTES: 1. Incorrect setting of the ribbon may cause it to come off. (See Fig. 26.)
2. Confirm that the ribbon is neither twisted nor creased and that the cartridge is set properly.

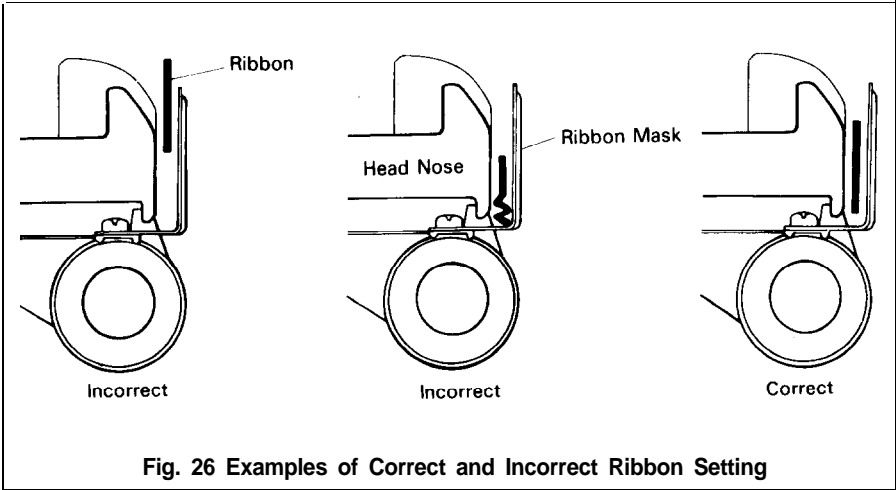

Fig. 26 Examples of Correct and Incorrect Ribbon Setting

5. Separator Installation

The separator of the Printer contributes to smooth paper feeding. Set the separator by inserting its edge into the two holes located at the rear part of the frame of the printer mechanism. (See Fig. 27.)

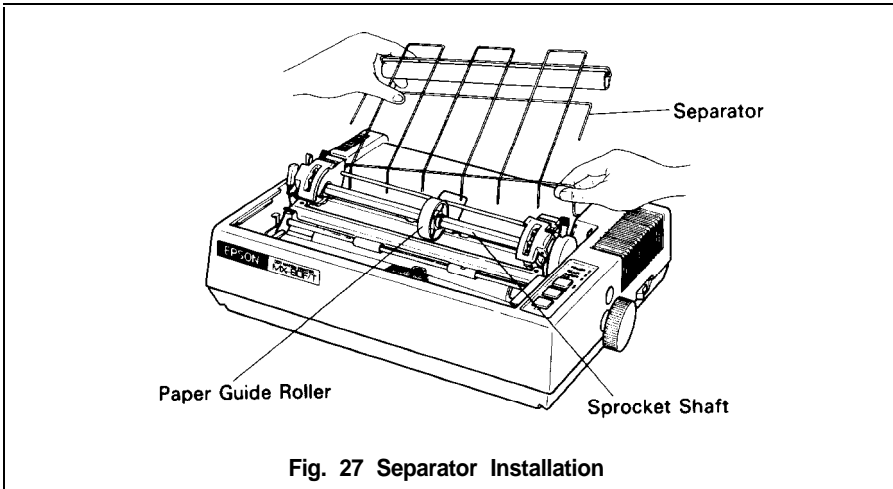

Fig. 27 Separator Installation

6. Dismounting of Tractor Unit

The tractor unit of the MX-80 F/T Type I I is detachable. If it is an obstacle when using roll paper, it can be taken out as follows;

STEP 1. Release the lock levers of the tractor unit by pulling in the direction as shown in Fig. 28.

STEP 2. Keep pulling the levers and pull up the tractor unit.

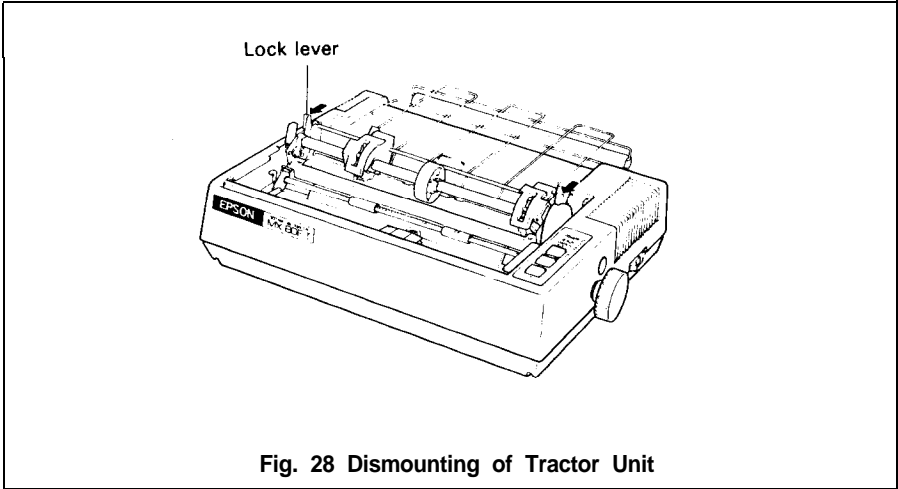

To install the tractor unit, hook the notches of the tractor frames onto the shaft shown in Fig. 29 and then push down the tractor unit.

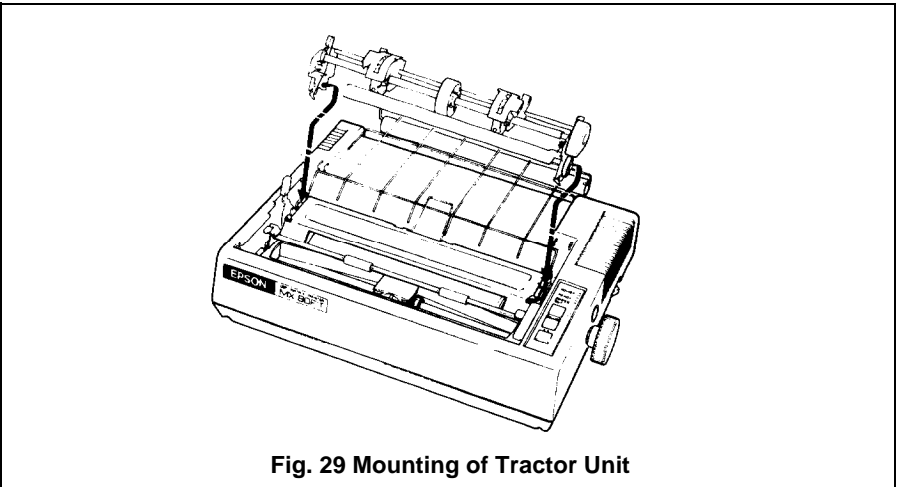

7. Paper Loading

7.1. Fanfold paper

7.1.1. Loading of fanfold paper

The MX-80 F/T Type I I Printer accommodates fanfold paper from 4" to 10" in width. To load the fanfold paper, observe the following procedure.

STEP 1. Raise the printer lid.

STEP 2. Unlock the release lever by pulling it in the direction of the arrow.
(See Fig. 30.)

STEP 3. Pull the scale toward the front of the Printer to detach the scale from the platen.

STEP 4. Confirm that the paper guide roller is at the center of the sprocket shaft. If not, set it at the center of the shaft.

NOTE: The paper guide roller contributes to smooth paper feeding.

STEP 5. Raise the two paper holding covers, and be sure to insert the fanfold paper between the frame and plastic roller of the separator. (See Fig. 30.)

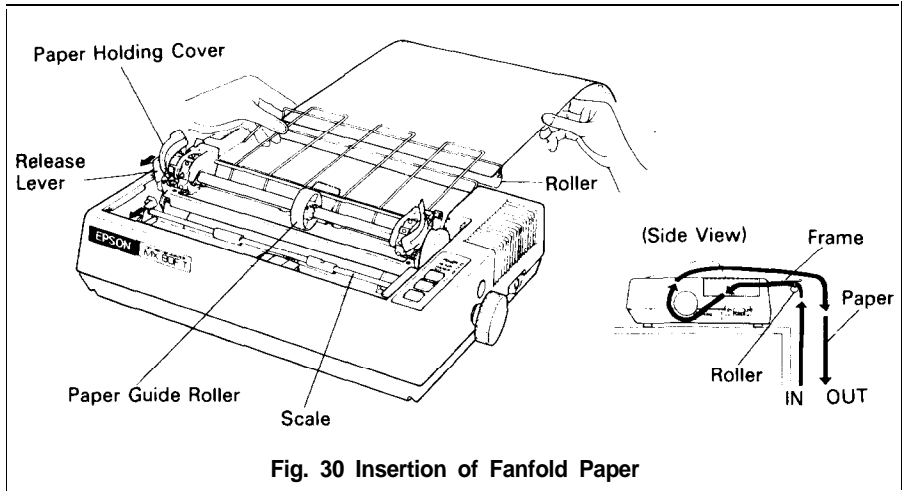

Fig. 30 Insertion of Fanfold Paper

STEP 6. Push the paper into the insertion slot between the paper guides at the rear part of the printer mechanism.

NOTE: Be sure to pass the paper beneath the upper paper guide.

Adjust the position of the head adjusting lever in the forward (+) direction when inserting thicker paper. (See Section 8, Gap Adjustment.)

STEP 7. After the leading edge of the paper has emerged from the Printer, pull it out gently to some length.

STEP 8. Raise the two sprocket lock levers to loosen, and adjust the sprocket pin position to the paper width. (See Fig. 31.)

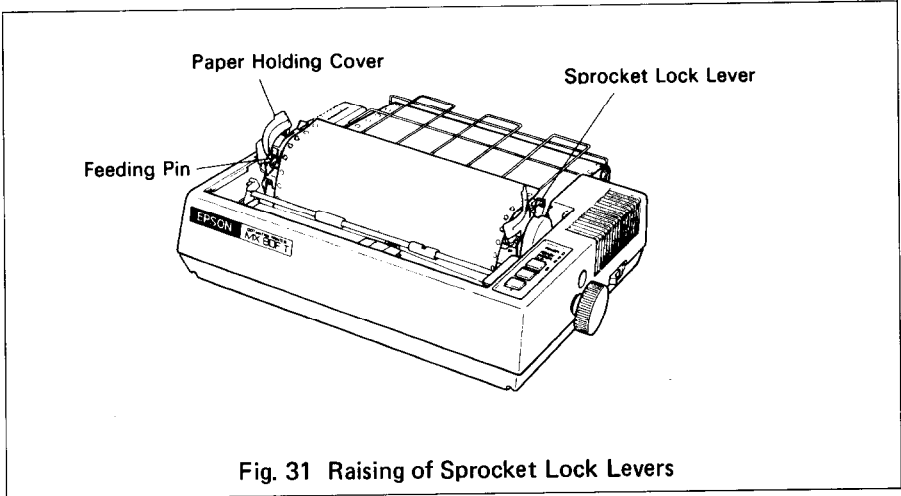

Fig. 31 Raising of Sprocket Lock Levers

STEP 6. Engage the paper feed holes of the paper on the feeding pins, push the scale back into position, and adjust the tension of the paper. Then push the paper holding covers and the two sprocket lock levers down. (See Fig. 32.)

NOTE: In this case, confirm that the feeding pins are centered in the respective paper feed holes of the paper. Do not lock the release lever.

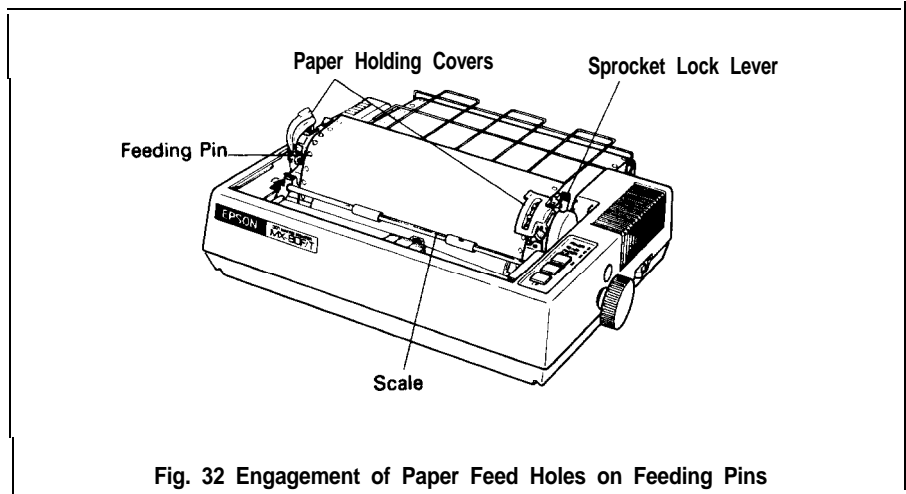

Fig. 32 Engagement of Paper Feed Holes on Feeding Pins

STEP 10. Put the printer lid on the Printer. (See Fig. 33.)

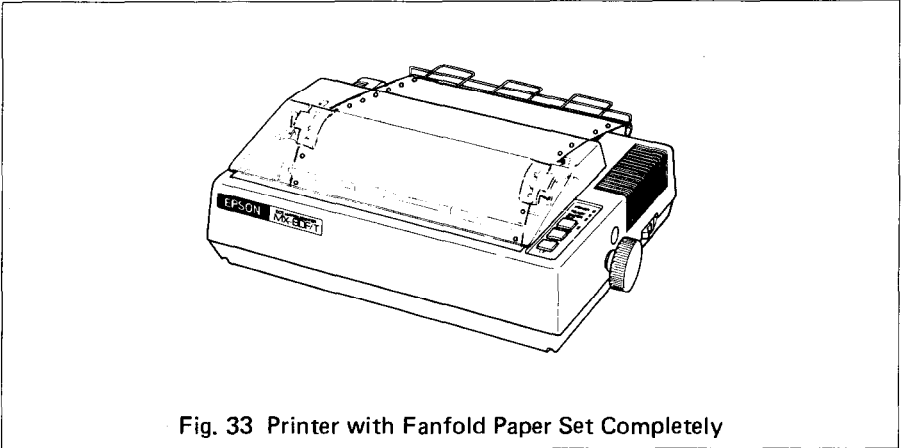

Fig. 33 Printer with Fanfold Paper Set Completely

NOTE: When the MX-80 F/T Type I is to be used on a desk or a bench, arrangement of the fanfold paper in parallel with the MX-80 F/T Type II as shown below will permit the paper to be folded in an accordion style.

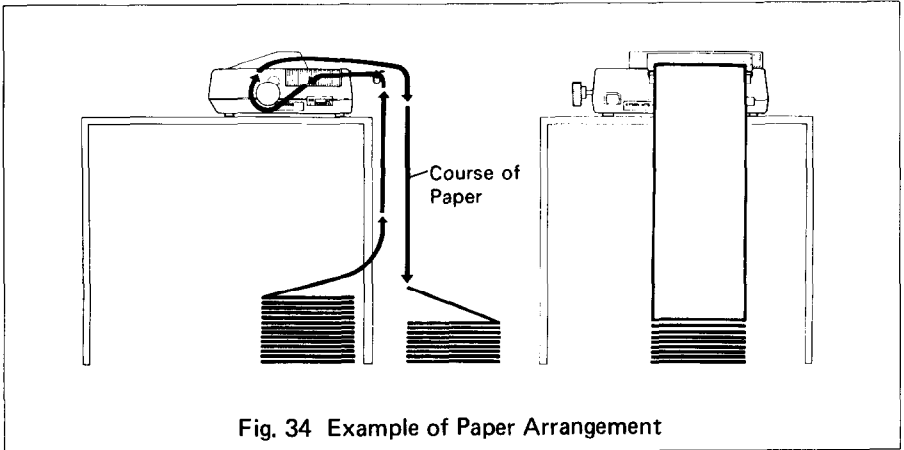

Fig. 34 Example of Paper Arrangement

7.1.2. Removal of fanfold paper

To remove the fanfold paper, follow either of the two methods described below.

- (1) To disengage the paper from the paper holding mechanism, pull it forward out of the Printer.

NOTE: Do not attempt to pull out the paper in the backward direction.

- (2) Feed the paper out of the Printer by electrical operation. For this, turn the Power Switch on and push the Line Feed button. (Details are described later.)

7.1.3. Column layout on fanfold paper

When fanfold paper of from 4" to 10" in width is supplied with the MX-80 F/T Type II, the graduations on the scale can be used as the indexes of print column positions (1 to 80). Alignment of the print start position on fanfold paper with the 1st column position at the extreme left of the scale will facilitate column layout. Accordingly, center the paper by adjusting it to these indexes of the scale.

7.1.4. Top of form position setting

The term "Top of Form position" is defined as the position in which the first print line lies on the form, and this position is determined when the power switch is turned on. Namely, adjust the paper position by the manual paper feed knob so that the required line position (i.e., the point at which the first line of the form is desired to be printed) is at the print head level. If, at this point, power is applied to the Printer, this line position automatically becomes the Top of Form position.

When printing forms, the matchmarks located on both the sprockets facilitate the setting of the Top of Form position on the fanfold paper. To set the Top of Form position, first enter (or preprint) a mark at a position on the edge of the paper 77mm above the first print line position of the paper, then align this mark with the matchmarks on the sprockets by turning the manual paper feed knob. At this point, turn the Power Switch on and the Printer will recognize this position as the Top of Form position. Now, the printing can be started from the Top of Form position.

(See Fig. 35.1)

In case of feeding one page of fanfold paper by operating the MX-80 F/T Type II by the input of FF code, the abovementioned adjustment is effective.

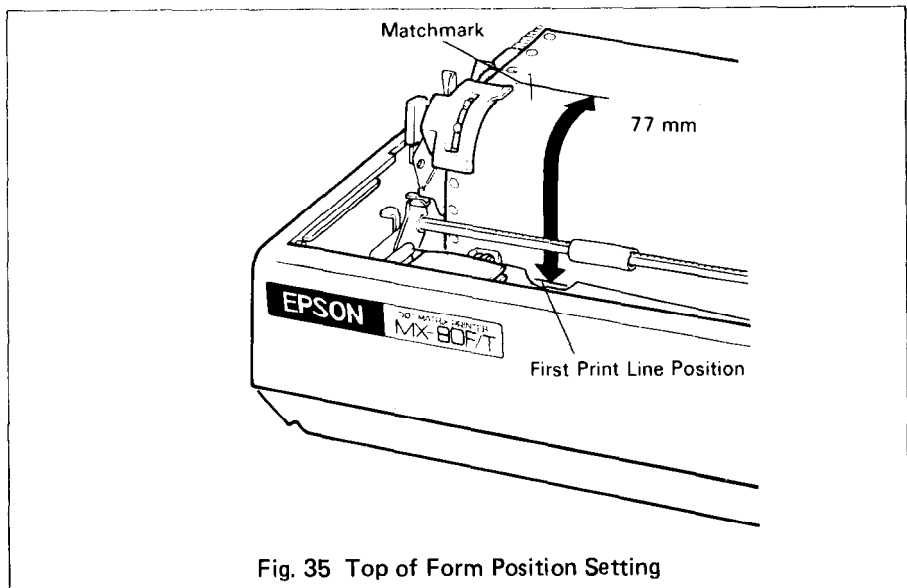

Fig. 35 Top of Form Position Setting

7.2. Roll paper

7.2.1. Roll paper holder

EPSON offers the roll paper holder as an optional accessory for the MX-80 F/T Type II. See Appendix 7 for the assembly instructions on Roll Paper Holder.

7.2.2. Loading of roll paper

The MX-80 F/T Type II accommodates a roll of single ply paper measuring 8.5 ±0.12 in. in width with a 1 in. core. To load it, observe the following procedure.

STEP 1. Raise the printer lid.

STEP 2. Unlock the release lever by pulling it in the direction of the arrow.
(See Fig. 36.)

STEP 3. Pull the scale toward the front of the Printer to detach the scale from the platen. (See Fig. 36.)

STEP 4. Confirm that the paper guide roller is at the center of the sprocket shaft. If not, set it at the center of the shaft. (See Fig. 36.)

NOTE: The paper guide roller contributes to smooth paper feeding.

STEP 5. Insert the end of the roll paper between the frame and the plastic roller of the separator. (See Fig. 36.)

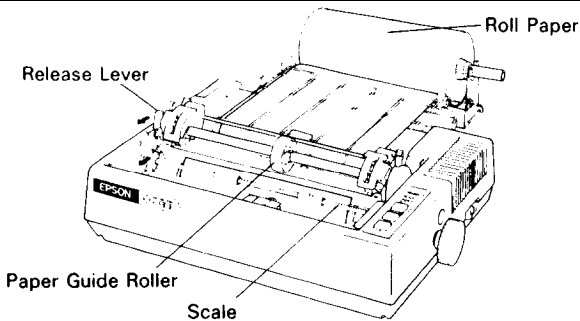

Fig. 36 Loading of Roll Paper (1)

STEP 6. Push the paper into the insertion slot between the paper guides at the rear part of the printer mechanism. (See Fig. 37.)

NOTES: 1. Be sure to pass the paper beneath the upper paper guide.

2. Two-ply roll paper is not recommended for use.

STEP 7. Lock the release lever and push the scale back into position. (See Fig. 38.)

STEP 8. While turning the manual paper feed knob clockwise, confirm that the paper advances straight up. If not, adjust the inserted paper position by unlocking the release lever.

STEP 9. Put the printer lid on the Printer.

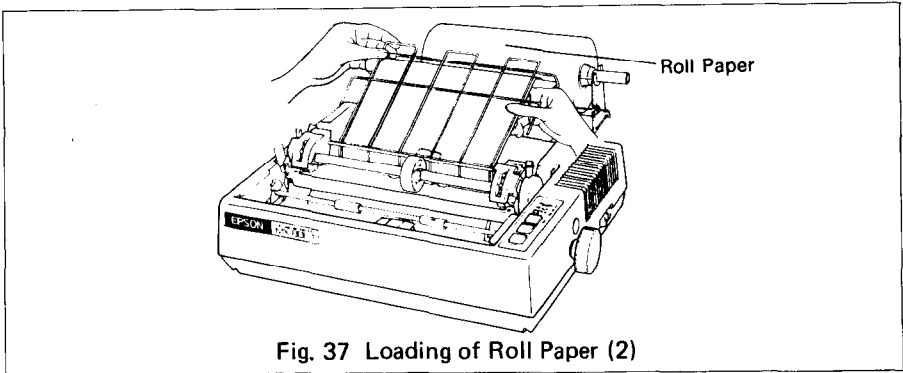

Fig. 37 Loading of Roll Paper (2)

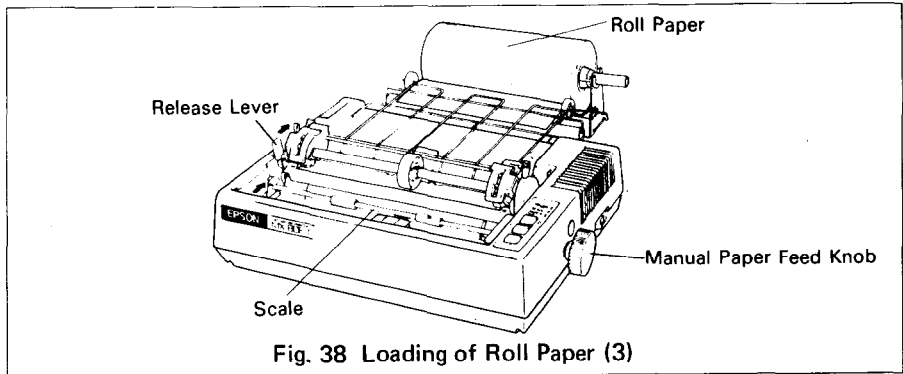

Fig. 38 Loading of Roll Paper (3)

7.3. Cut paper sheet

7.3.1. Loading of cut paper sheet

The MX-80 F/T Type I accommodates cut paper sheets measuring 8.3" to 8.5" in width. To load a cut paper sheet, observe the following procedure.

STEP 1. Raise the printer lid.

STEP 2. Unlock the release lever. (See Fig. 39.)

STEP 3. Pull the scale toward the front of the Printer to detach the scale from the platen. (See Fig. 39.)

STEP 4. Confirm that the paper guide roller is at the center of the sprocket shaft. If not, set it at the center of the shaft.

NOTE: The paper guide contributes to smooth paper feeding.

STEP 5. Insert the cut paper sheet between the paper guides at the rear part of printer mechanism.

NOTE: The paper sheet can be installed without removing the separator.

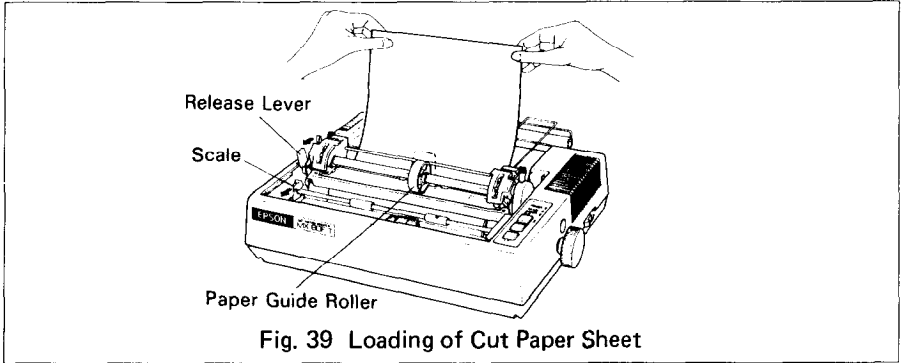

STEP 6. Lock the release lever.

STEP 7. While turning the manual paper feed knob clockwise, confirm that the paper advances straight up. (See Fig. 40.)

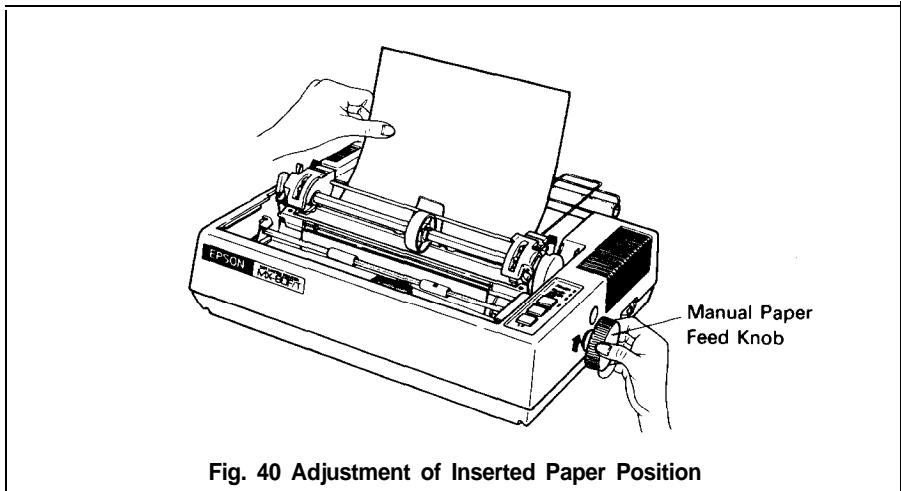

If not, adjust the inserted paper position as follows:

- a) If the cut paper sheet or form is long enough, unlock the release lever and align the side edges of the paper as shown in Fig. 41.

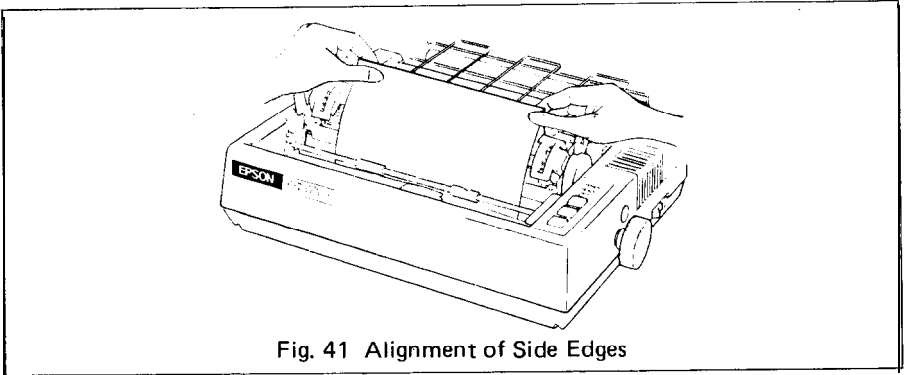

Fig. 41 Alignment of Side Edges

- b) If the cut paper sheet or form is not long enough to align the side edges, align the top edge of the paper with the form position setting mark on the tractor unit. (See Fig. 42.)

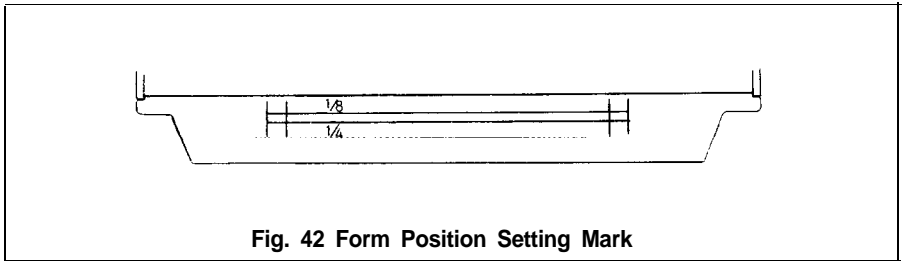

Fig. 42 Form Position Setting Mark

The print area on the cut paper sheet (when printing it with the tractor unit installed) is shown in Fig. 43

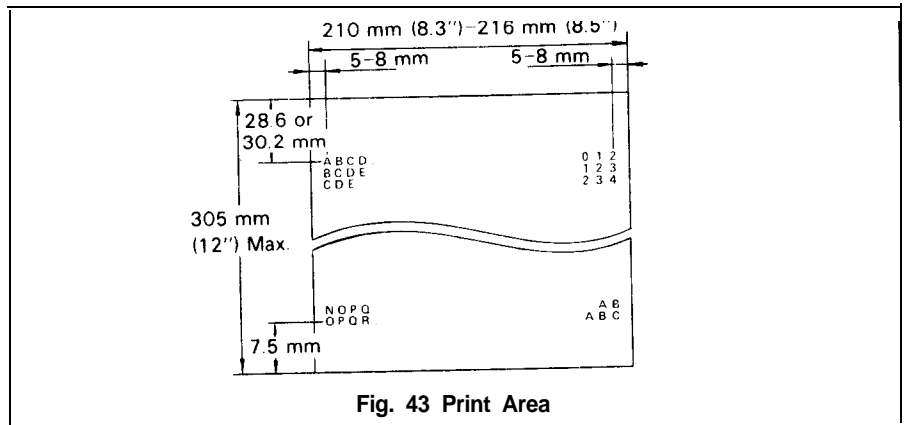

Fig. 43 Print Area

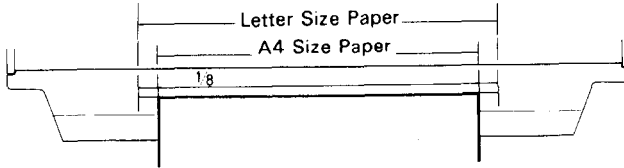

Fig. 44 Setting of Cut Paper Sheet

NOTES: 1. The Paper End Detector function may be disabled under software control (ESC 8; refer to page 66) provided printing is left off within 7.5 mm from the paper bottom edge.

2. If the paper is set on the line marked 1/4 as shown in Fig. 44, then the printing starts from a position 28.6 mm below the top edge of the paper. If the paper is set on the line marked 1/8, then the printing starts from a position 30.2 mm below the top edge of the paper.

STEP 8. Push the scale back into position and put the printer lid on the Printer. (See Fig. 45.)

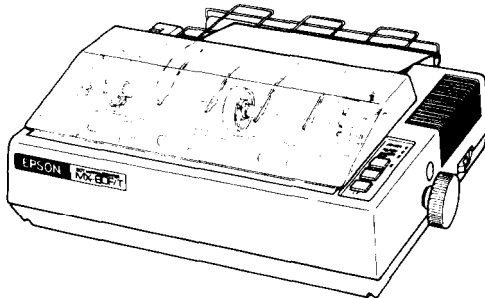

Fig. 45 Printer with Cut Paper Sheet Set Completely

8. Gap Adjustment

The adjustment of a gap between the head nose and the platen is used to adjust the printing pressure as well as to suit paper of a different thickness.

- (1) Move the head adjusting lever (located on the left frame of the Printer) forward or backward to adjust the gap between the head nose and the platen.

(See Fig. 46.)

Forward: To widen gap.

Backward: To narrow gap.

NOTE: With a thick paper, be sure to widen this gap.

- (2) Adjust the position of the head adjusting lever according to the type of paper to be used.

Paper	Position of adjusting lever
Single-leaf paper	Set the lever to the 4th step.
Carbon paper sheets	Set the lever to the 7th step.

- (3) Should printed characters become faint due to the use of the Printer for an extended period, move the head adjusting lever backward (in the \ominus direction) by one step. (See Fig. 46.)
- (4) When a set of carbon paper sheets is used, be sure that no characters are printed within the area two lines each above and below the perforation.

9. Power Connection

The EPSON MX-80 F/T Type I I Dot Matrix Printer is capable of operating on the following three types of AC power.

- (1) 115V AC, 60Hz
- (2) 220V AC, 50Hz
- (3) 240V AC, 50Hz

Before connecting the MX-80 F/T Type II to a power source, make certain of the primary AC rating from the label located on the chassis at the rear of the Printer. After connection of the Printer to the proper power source and upon application of power to the Printer, "Initialization" will take place in the Printer with the effects described in paragraph 1.4, Appendix 1. If your MX-80 F/T Type II has a primary AC rating different from the available power source, do not attempt to operate the Printer. Please obtain a replacement unit with the correct AC rating from the store where you purchased the MX-80 F/T Type I I.

Head Adjusting Lever

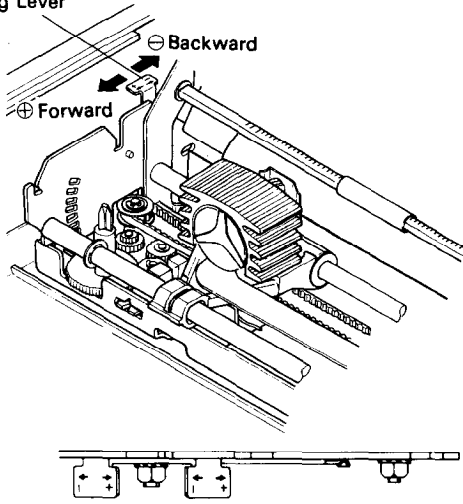

⊖ Backward ←→ Forward ⊕

Head Adjusting Lever

(Side view)

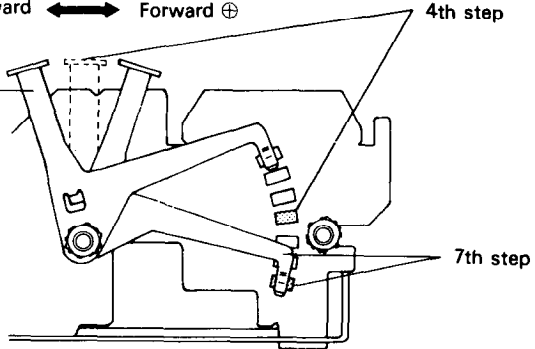

Fig. 46 Gap Adjustment

OPERATION

1. Switches and Indicators

There are three switches and four indicators (green LED's) on the control panel and one power switch on the right side of the Printer case. In this section, panel operating procedures are covered in sufficient detail for the user to become familiar with the Printer. (See Fig. 47 for the control panel.)

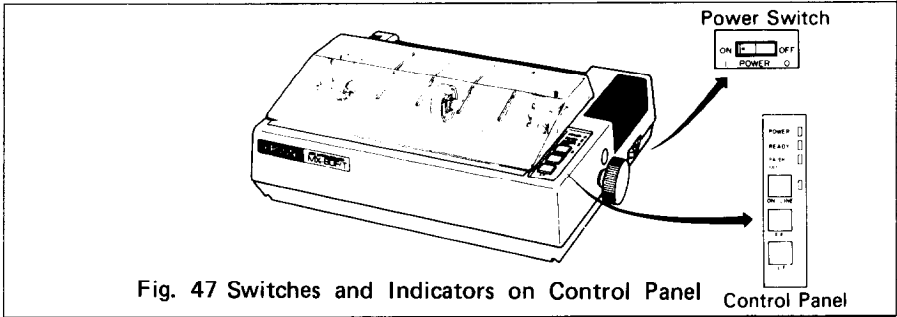

Fig. 47 Switches and Indicators on Control Panel

1.1. Switches

POWER SW: Controls primary AC power to the Printer.

NOTE: Before turning this switch on, check to see if the paper is properly set in the Printer.

Incorrect setting of the paper may prevent the Printer from operating properly.

ON LINE SW: When the power switch is turned on after paper has been loaded, the Printer enters the ON-LINE mode and can be utilized in conjunction with a host computer.

Depressing the ON-LINE switch will set the Printer in the OFF-LINE mode and cause the green LED to go out. The switch does not function while the Printer is actively engaged in printing. The Printer is automatically placed OFF-LINE if the paper supply is exhausted or if a mechanical error occurs in the Printer.

The operations of the Line Feed and Form Feed switches are effective only while the Printer is OFF-LINE.

FF SW: When this switch is depressed once, the paper is advanced vertically to the next Top of Form position. This switch must be depressed while the Printer is OFF-LINE. Otherwise, the form feed operation will not be carried out.

(Form Feed)

The Top of Form position is initialized when the POWER switch is turned on or when INIT signal is applied to the interface connector. Therefore, before turning the POWER switch on to start operating the Printer, set the paper at the appropriate Top of Form position.

LF SW: The paper advances while this switch is being depressed.

(Line Feed)

The line spacing for paper advancement is determined by ESC A + n code (described later). When the Power switch is turned on, the line spacing is initialized at 1/6 inch.

The line feed operation is prohibited while the Printer is actively engaged in printing.

1.2. Indicators

POWER: Illuminates while the Printer is receiving AC power.

READY: Illuminates when the Printer is ready to receive data.

PAPER OUT: Illuminates when the paper supply is near its end.

ON LINE: Illuminates when the Printer is in the ON-LINE mode.

1.3. Printer initial check

Take the following steps and become familiar with the Printer.

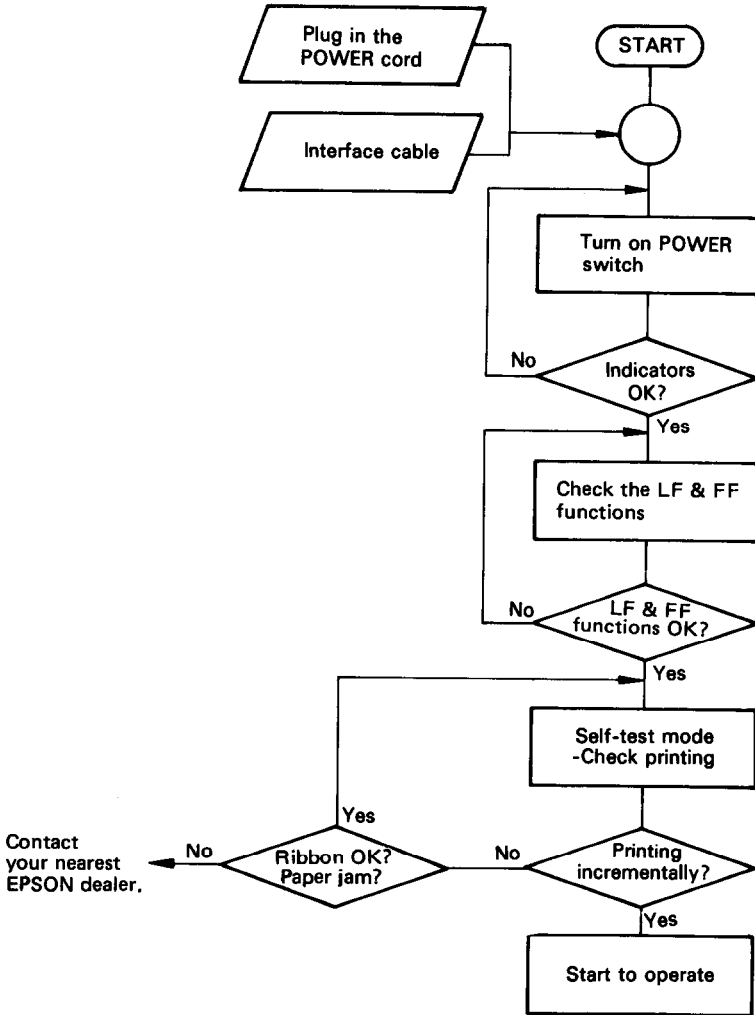

Fig. 48 Printer Initial Check

2. Buzzer

The buzzer is located inside the Printer case, and sounds for about one second when the Printer receives BE L code (<07>H). (See page 66 for the BE L code.)

3. Paper End Detector

- (1) When the paper end detector (a reed switch located on the paper guide) detects that the paper is nearly exhausted, the signals on the interface connector change to the following status, and the printing operation stops.

Table 1 Interface Signals in Paper-Out Status

Signal	Pin No.	Status
ERROR	32	"LOW" level
PE (Paper End)	12	"HIGH" level
BUSY	11	"HIGH" level
ACKN LG	10	No pulse is output

To reactivate the printing, take the following procedure as shown in Fig. 49.

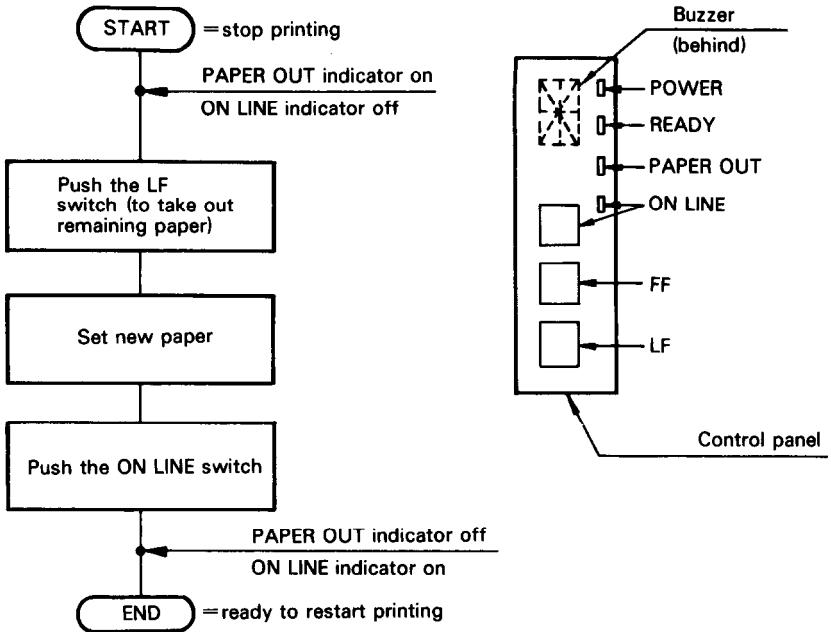

Fig. 49 Flowchart of Paper Out Status Release Procedure

- (2) When the Printer falls into paper-out status, it is automatically put in the OFF-LINE state and paper advancement can be performed by depressing the LF switch.

After setting new paper in the Printer, depress the ON LINE switch so that the Printer may resume operation.

- (3) There is another way to start the Printer again when it falls into paper-out status. Set new paper in the Printer, and turn the POWER switch off and on again, or apply the INIT signal. In this case, however, all previously established data such as TAB, line spacing, etc. are cancelled.
- (4) The paper end detecting function is useful to prevent erroneous printing when the Printer is out of paper. If printing of characters up to the last line is to be continued, the paper end detecting function may be made invalid by either of the following two methods.
- Set the DIP switch pin 1-6 to the ON position, and the paper end detecting function will become invalid hardwarewise.
 - Enter control code "ESC 8" and the paper end detecting function will become invalid softwarewise.

4. Self -Test

The MX-80 Type I I has a self-test (self-diagnostic) function to check the following.

- Print head operation and printing quality
- Operation of the printer mechanisms (motor, cartridge ribbon mechanism, belt, etc.)

The self-test function is pre-programmed and can be performed by turning the POWER switch on while depressing the LF switch. All characters provided by the internal software are printed out on the paper by this operation.

```
( ) * + , - . / 0 1 2 3 4 5 6 7 8 9 : ; < = > ? @ A B C D E F G H I J K L M N O P Q R S T U V W  
) * + , - . / 0 1 2 3 4 5 6 7 8 9 : ; < = > ? @ A B C D E F G H I J K L M N O P Q R S T U V W X  
* + , - . / 0 1 2 3 4 5 6 7 8 9 : ; < = > ? @ A B C D E F G H I J K L M N O P Q R S T U V W X Y  
+ , - . / 0 1 2 3 4 5 6 7 8 9 : ; < = > ? @ A B C D E F G H I J K L M N O P Q R S T U V W X Y Z  
, - . / 0 1 2 3 4 5 6 7 8 9 : ; < = > ? @ A B C D E F G H I J K L M N O P Q R S T U V W X Y Z I
```

- NOTES:
- The self-test function cannot be performed when the printer is out of paper.
 - To check all interface logic including the interface connector, proceed as follows:
 - Connect ACKNLG signal pin No. 10 to STROBE signal pin No. 1 with a lead wire.
 - Turn the DIP switch 2-3 (on the control circuit board) ON to effect auto-line feed.
 - Set the adequate ASCII code data to be printed. To obtain low logic level signals, connect the data transfer line required for printing (pin Nos. 2 to 9) to GND level (pin No. 33, etc.)

* Example of printing "Z"

"Z" = [5, A]_n (01011010)

In this case, connect pin Nos. 2, 4, 7 and 9 to pin No. 33.

5. Setting of DIP Switches

In order to suit the user's specific requirements, desired control modes are selectable by the two built-in DIP switches. The DIP switches (SW1 and SW2) located on the control circuit board of the Printer are as shown in Fig. 54. To gain access to the DIP switches, the upper case of the Printer must be removed.

NOTE: Turn the power off whenever you attempt to open up the printer case. Adequately discharge static electricity which might be charged in your body, or it may cause damages to internal electronic parts such as LSI's, IC's, etc.

Remove the manual paper feed knob (black knob on the right side) by pulling it straight out, with firm but steady pressure. (See Fig. 50.)

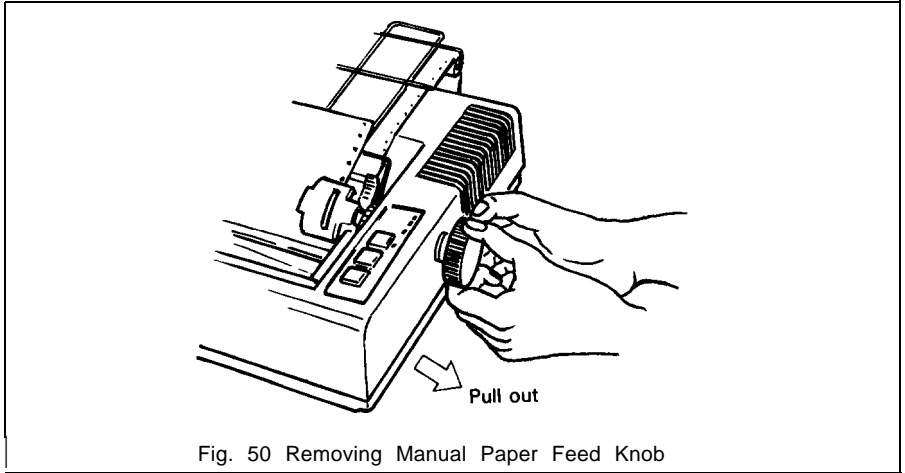

Turn the printer upside down on a soft surface. With a Phillips type screwdriver completely loosen all 4 screws. (See Fig. 51.)

Place tape over the 4 holes so the screws won't fall off when you tip the printer right side up.

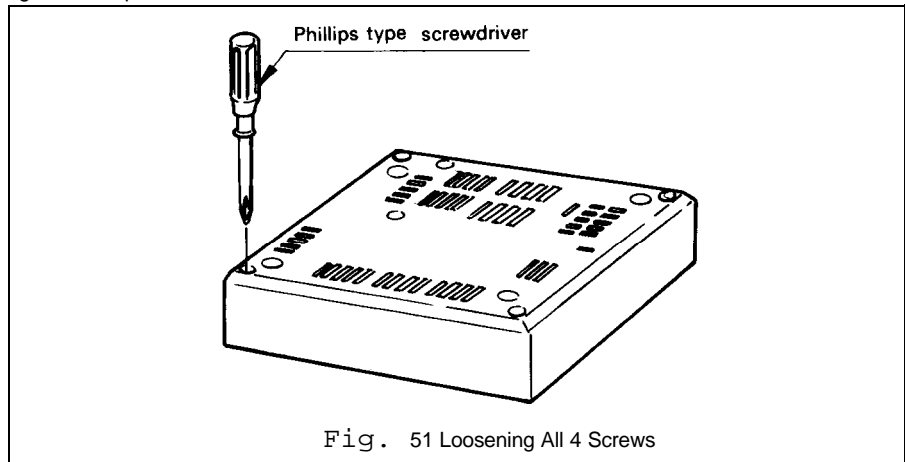

Tip the printer right side up again. Gently loosen the upper case. Lift up the cover from the left side. And then pull out the wires hooked to the control panel on the right. (See Fig. 52.)

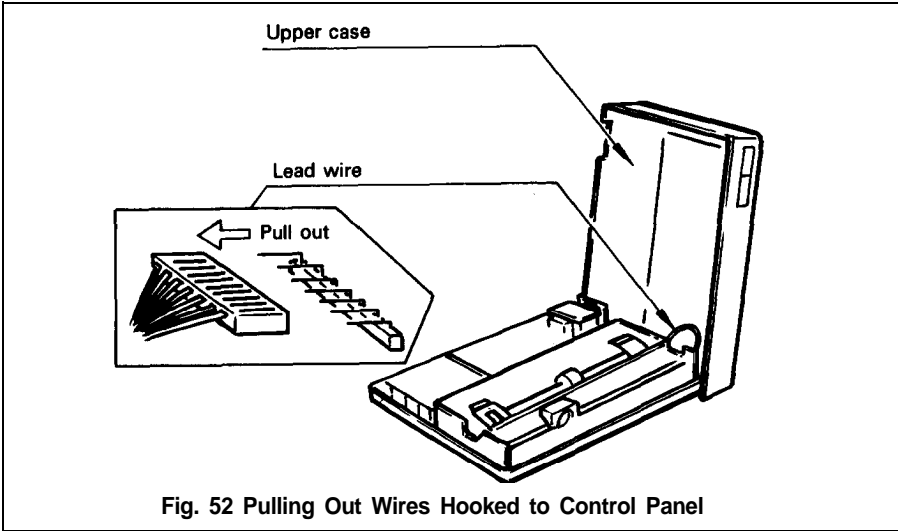

Fig. 52 Pulling Out Wires Hooked to Control Panel

See the inside of the printer before you set the switches.
 The printer consists of a printer mechanism, a controller, a transformer and filter circuit board, and a control panel. (See Fig. 53.)

Construction of the Printer

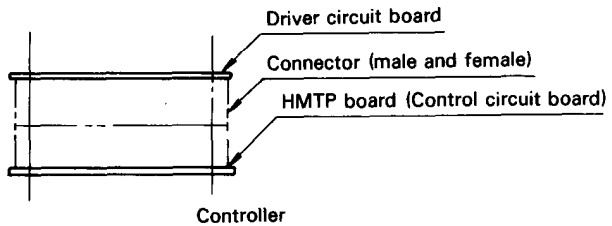
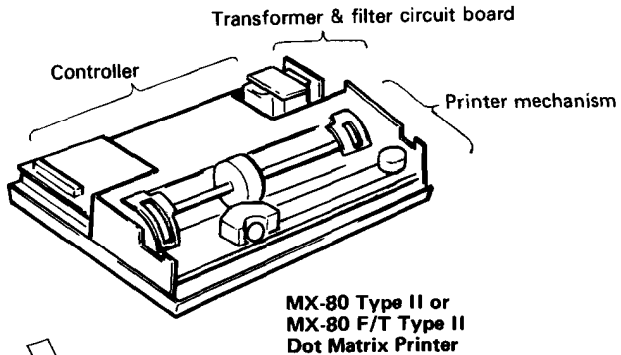
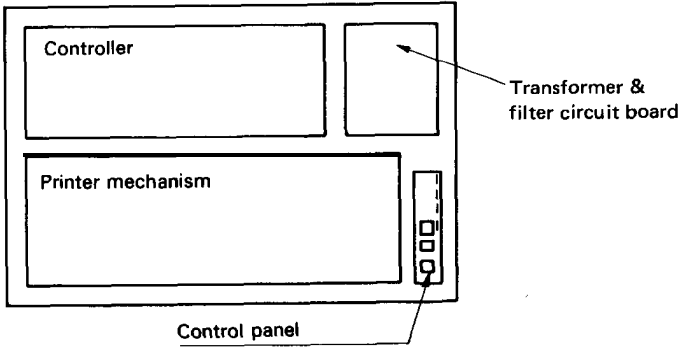

Fig. 53 Construction of Type II Printer

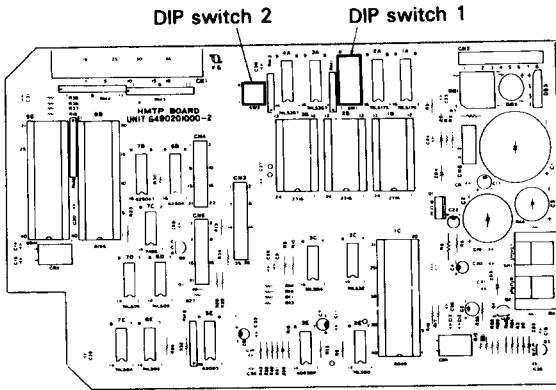

Fig. 54 Location of DIP Switches

Position the printer as shown in Fig. 53.

There are two "DIP" (DUAL IN-LINE PACKAGE) switches in the HMTD board. (See Fig. 54.) The switches set to the left are ON . . . to the right are OFF. (See Fig. 55.)

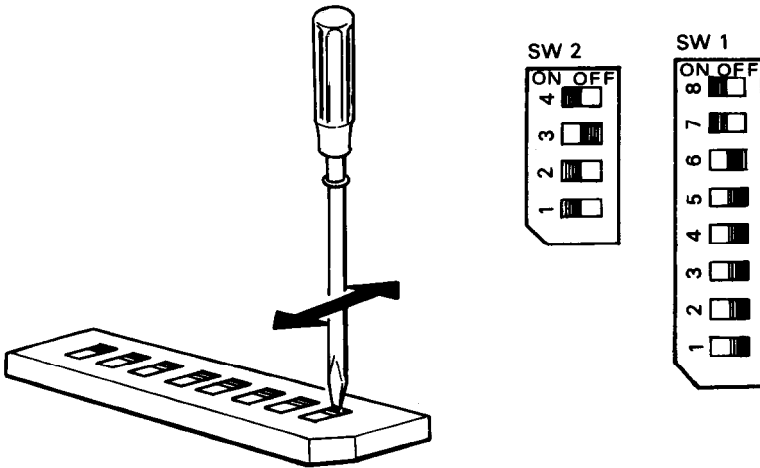

Fig. 55 Setting DIP Switches

Each switch No. of the DIP switch functions as described below. So set these switches to suit your application or the computer's specifications.

NOTE: Be sure that the **POWER** switch of the printer is turned off before changing switch positions.

5.1. Setting of DIP Switch No. 1

The DIP switch No. 1 consists of the following 8 pins.

A summary of the functions of the respective DIP switch pins and their preset conditions at the time of shipment are shown in Table 2.

Table 2 Functions and Conditions of DIP Switch No. 1

SW pin No.	Function	OFF	ON	Factory-set condition
1-1	Line spacing	1/8"	1/8"	OFF
1-2	Form length	11"	12"	OFF
1-3	Character size	See Table 3.		OFF
1-4	Character size	See Table 3.		OFF
1-5				OFF
1-6	Paper end detector	Valid	Invalid	OFF
1-7	International character set	See Table 5.		
1-8	SLCT IN signal internally fixed or not fixed	Not fixed	Fixed	ON

- (1) SW1-1: Setting this pin to the ON position will cause the line spacing to be automatically set at 1/8 inch per line upon power application.
- (2) SW1-2: Setting this pin to the ON position will cause the form length per page to be set at 12 inches. The form length per page becomes 11 inches when this pin is set to the OFF position.
- (3) SW1-3 & 1-4: Combined use of these two pins permits selection of the number of columns per line as shown in Table 3.
- (4) SW1-5: Never set this pin to the ON position. Always leave it in the OFF position.
- (5) SW1-6: This pin is used to activate or inactivate the paper end detector. When this pin is turned on, the paper end detecting function becomes invalid upon power application and the Printer is allowed to operate even if it is out of paper. With the Printer in this state, input of control code "ESC 9" will permit the paper end detector to be activated again.
- (6) SW1-7: This pin is used to select an international character set in conjunction with DIP switch No. 2 upon power application.
- (7) SW1-8: When this switch is set to the OFF position, SLCT IN signal is not fixed internally, thus permitting the Printer to be controlled from a host computer.

NOTE: This signal line is wired O Red with the pin No. 36 of the interface connector. Therefore, to control the signal level with the pin No. 36 of the interface connector from the external CPU through TTL, etc., leave this DIP switch pin to the OFF position.

- (8) Character sizes and maximum column lengths can be specified as follows;

Table 3 Character Size and Maximum Column Length

Character size	Pin number		Maximum column length	Default length
	SW1-3	SW1-4		
Normal	OFF	OFF	80	80
Condensed	OFF	ON	132	132
Emphasized	ON	ON	80	80

If you turn any of the above character sizes to the enlarged character print mode, then the maximum column length will be reduced to a half of them.

5.2. Setting of DIP switch No. 2

The DIP switch No. 2 consists of the following 4 pins. A summary of the functions of the respective DIP switch pins and their preset conditions at the time of shipment are shown in Table 4.

Table 4 Functions and Conditions of DIP Switch No. 2

SW pin No.	Function	OFF	ON	Factory-set condition
2-1	International character set	See Table 5.		
2-2	International character set	See Table 5.		
2-3	AUTO FEED XT signal internally fixed or not fixed	Not fixed	Fixed	OFF
2-4	1 inch skip-over perforation	Valid	Invalid	ON

- (1) SW2-1 & 2-2: Combined use of these two pins and SW1-7 permit selection of the international character set for U.S.A., France, Germany, England, Denmark, Sweden, Italy, and Spain as shown in Table 5 upon power application.
- (2) SW2-3: This pin is used to fix AUTO FEED XT signal internally. (Refer to the explanation of control code "CR" in paragraph 3.1 (1) "WHAT IS THE MX-80 TYPE II?") This signal line is wired ORed with the pin No. 14 of the interface connector. Therefore, to control the pin No. 14 externally through TTL, etc., leave this DIP switch pin to the OFF position.
- (3) SW2-4: This pin is used to set the automatic skip-over perforation function.
 - (a) When this pin is set to the OFF position, the automatic skip-over perforation function becomes valid. By this function, the paper automatically advances to the first line of the next page when the remaining page length is 1 inch.
 - (b) When this pin is set to the ON position, the 1-inch automatic skip-over perforation function becomes invalid. However, you can activate this function programmably (described in detail later).

5.3. Coding tables

Appendix 3 shows all available codes when the Printer is set for operation with standard coding by setting the DIP switch pins 1-7, 2-1 and 2-2 all to ON position. Table 5 shows International Character Set Designation according to the combination of the DIP switch setting.

Table 5 International Character Set Designation

SW1-7	SW2-1	SW2-2	Country
ON	ON	ON	U.S.A.
ON	ON	OFF	FRANCE
ON	OFF	ON	GERMANY
ON	OFF	OFF	ENGLAND
OFF	ON	ON	DENMARK
OFF	ON	OFF	SWEDEN
OFF	OFF	ON	ITALY
OFF	OFF	OFF	SPAIN

The above settings can be changed to any country character sets by inputting ESC R + n control codes. (Described later.)

The above countries' characters are addressed as per the following table.

Table 6 International Character Sets

Country Hex. code	U.S.A.	France	Germany	England	Denmark	Sweden	Italy	Spain
23	#	#	#	£	#	#	#	Pt
24	\$	\$	\$	\$	\$	Ø	\$	\$
40	@	à	§	@	@	É	@	@
5B	[°	Ä	[Æ	Ä	°	í
5C	\	ç	Ö	\	φ	Ö	\	Ñ
5D]	§	Ü]	Å	Å	é	¿
5E	^	^	^	^	^	Ü	^	^
60	•	•	•	•	•	é	û	•
7B	{	é	ä	{	æ	ä	à	~
7C		ü	ö		φ	ö	ò	ñ
7D	}	è	ü	}	á	ä	è	}
7E	~	~	β	~	~	ü	ì	~

5.4. Setting sequence of functional specifications

The MX-80 Type I I has a choice of various functional specifications such as amount of line spacing, form length per page, number of columns per line, automatic skip-over perforation, etc. for selection under the control of both hardware (DIP switches) and software (control codes) which is described later. In Figs. 56 through 59, setting sequence of these functional specifications are illustrated.

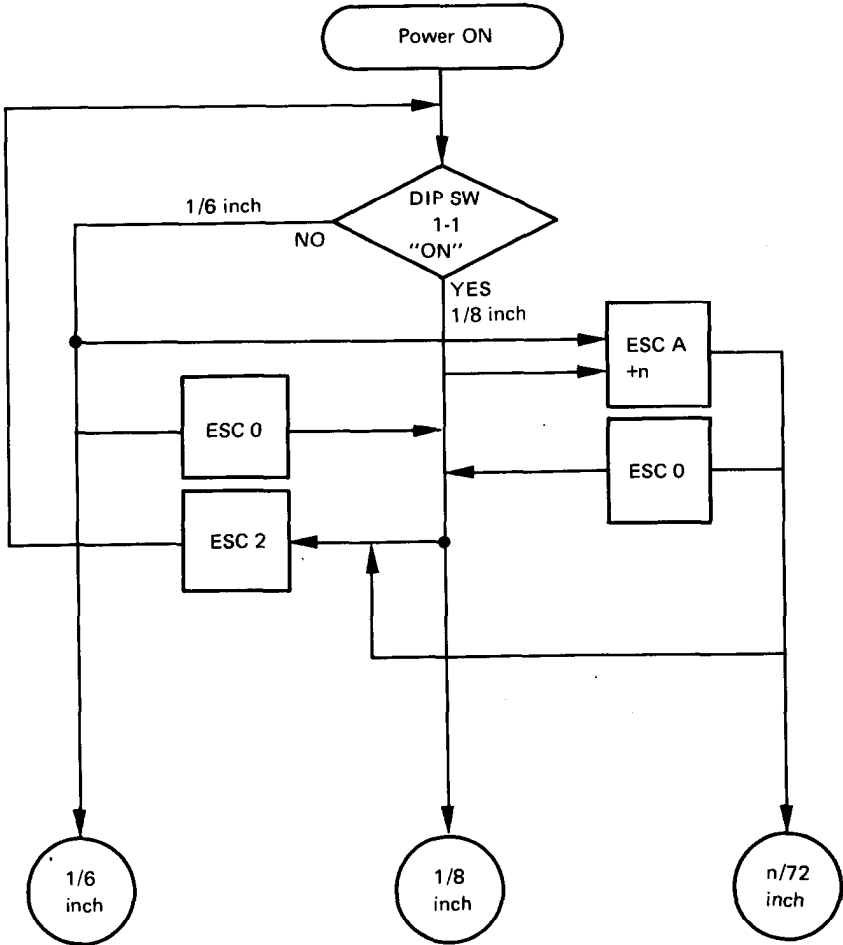

Fig. 56 Setting Amount of Line Spacing

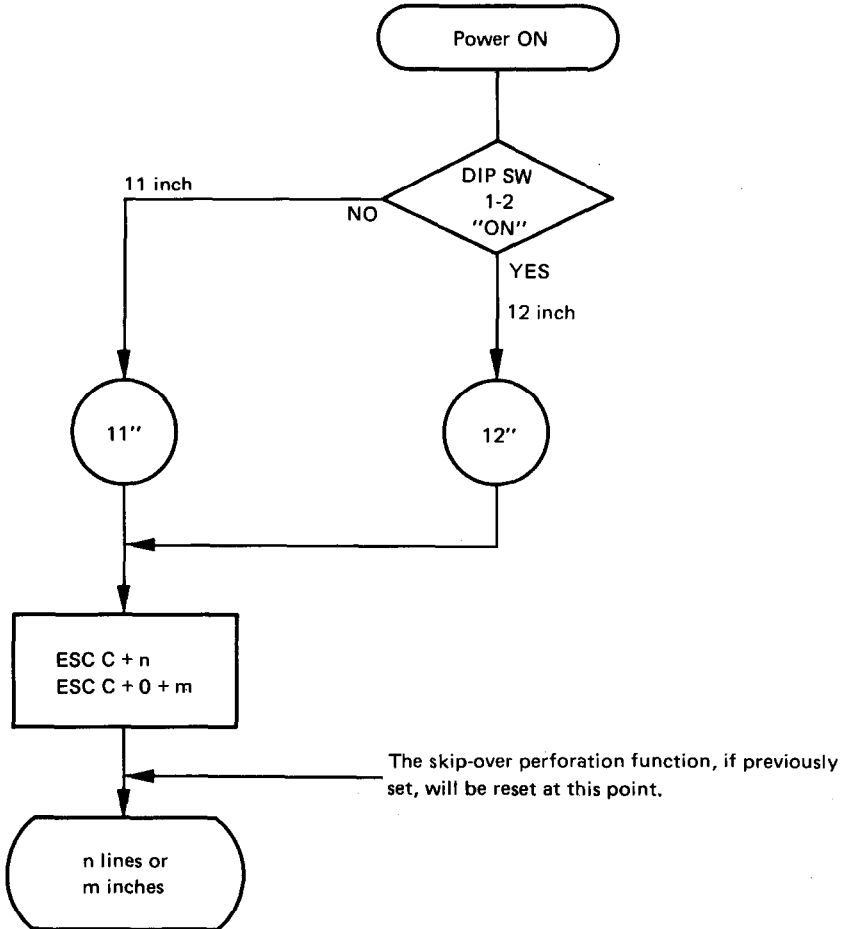

Fig. 57 Setting Form Length per Page

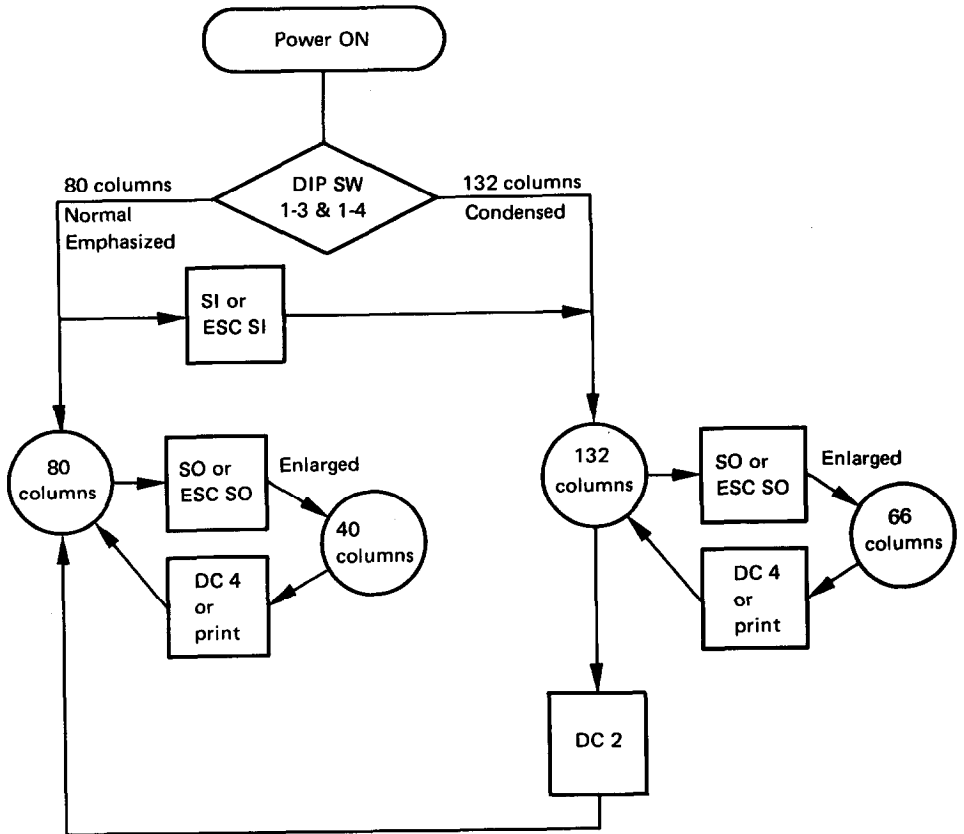

Fig. 58 Setting Number of Columns per Line

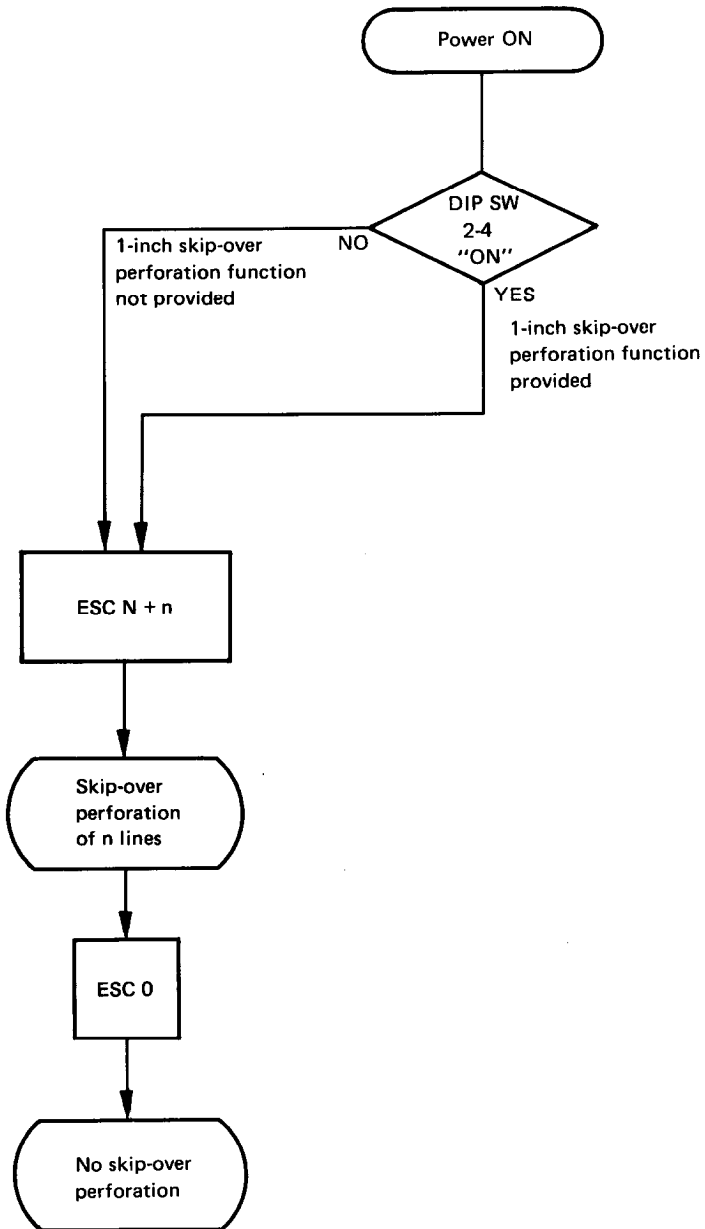

Fig. 59 Setting Skip-over Perforation Function

WHAT IS THE MX-80 TYPE II?

This chapter describes the MX-80 Type II from the viewpoint of hardware and software.

The contents of the chapter are;

- 1, What is a dot matrix printer?
2. Definitions of some terms often used.
3. Control codes in the text mode
4. Control codes in the bit image mode

This printer has two different print modes. One is the text mode, and another is the bit image mode. You might be familiar with the text mode because an ordinary printer has it.

In this mode a printer prints alphabets, numbers and some special symbols. On the other hand, you probably do not understand the word "Bit Image." In short the bit image mode allows you to control each of the needles called "dot wires" freely and programmably. As a result, you can get screen hard copies including graphic patterns defined arbitrarily or can specify any character and character formation except pre-designed matrix. The full graphics or full dot image print may be easier to understand. But we define its print mode as "Bit Image."

1. What Is a Dot Matrix Printer?

As you know, many kinds of printers are marketed in the world, and they may be classified by categories such as impact or non-impact printing method, line or serial printing method and so on.

Broadly speaking, the EPSON MX-80 Type I I belongs to the following categories.

- Impact printer
- Dot Matrix printer
- Serial printer with one line buffer
- Receive only printer

(This printer might be sorted to another category.)

The impact printer means that it impacts ribbon with carbon and forms the characters you want.

The serial printer means that it cannot print data at the same time like a line printer and the print speed will be slower. But if the printer has buffer memory, it can store data for a while in the buffer memory and then print at almost the same time. The receive only printer means that it cannot send data to a computer or another equipment except a limited number of interface signals, i.e., it does not have a keyboard.

The dot matrix printing method allows a printer to easily form any desired character. It has a print head that contains 9 needles vertically and can create distinctive characters like with typewriter. In that sense it is one of the key features that the printer has. EPSON's MX-80 Type II can control each needle programmably, expanding the ability of the printer.

See next how the print head works and forms a character.

(1) Dot Matrix Printer

The print head contains 9 “needles” or “wires” vertically. Each dot wire is driven by an electromagnet which fires when told to do so by the electronics inside the printer.

Signals from the computer cause the appropriate dot wires to be fired from the holder and to impact carbon, causing the character to be printed as a series of dots.

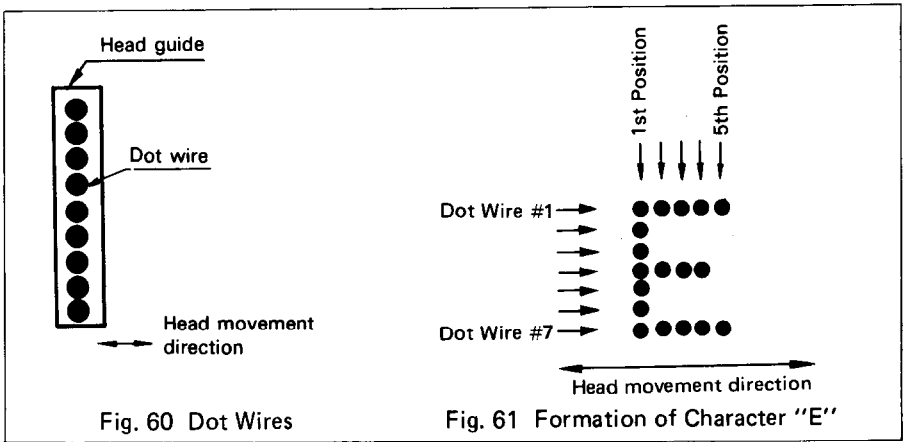

As an example (see Fig. 61). to print the letter "E", dot wires 1 through 7 are fired first. They hit the ribbon. That makes marks on the paper. Then the head shifts over a bit and dot wires 1, 4 and 7 are fired. In this manner, the character "E" is formed.

This is called "Dot Matrix Printing".

Dots are printed according to a pre-designed "Matrix" or "Grid" system, where each letter, number and punctuation mark is formed by arrangement of dots. In the above figure, the print head moves from left to right. Since the MX-80 Type II is a bidirectional printing type, the head can also move from right to left to print characters.

NOTE: In the Text mode, a maximum of 7 dot wires are used for character formation.
See Appendix 4, Character Fonts.

(2) Character and line spacing

Line spacing means the pitch from the top of dots that form a character on a line to the top of dots on the next line.

It is absolutely necessary to separate characters vertically for ease in reading each sentence. Most typewriters and printers have a switch or lever to change the line spacing (1/6" or 1/8"). The MX-80 Type II also can do this by DIP switch setting, of course. In addition, you can set it programmably with some ESC codes with a range from 1/72" to 85/72".

See what happens when you set the line spacing to 1/8" and 1/6".

Look at the following figures, (a) and (b). The line spacing, i.e. the pitch from the top of upper "g" or "G" character to the top of the "g" or "G" on the next line is 1/8". That corresponds to 9-dot skipping. If you type a "g" on the first line and a "G" on the next line, the 2 characters will be close to each other. This is a little bit hard to read in a long message including upper case characters and lower case ones. In other uses, however, this line spacing is effective. You can understand its effectiveness when using the bit image mode.

On the other hand, with 1/6" line spacing, there is no problem even if upper case characters and lower case ones are mixed in a message. In this case, a minimum of 1/24" line spacing is created between characters vertically. If you want greater line spacing or less, input the ESC A control code.

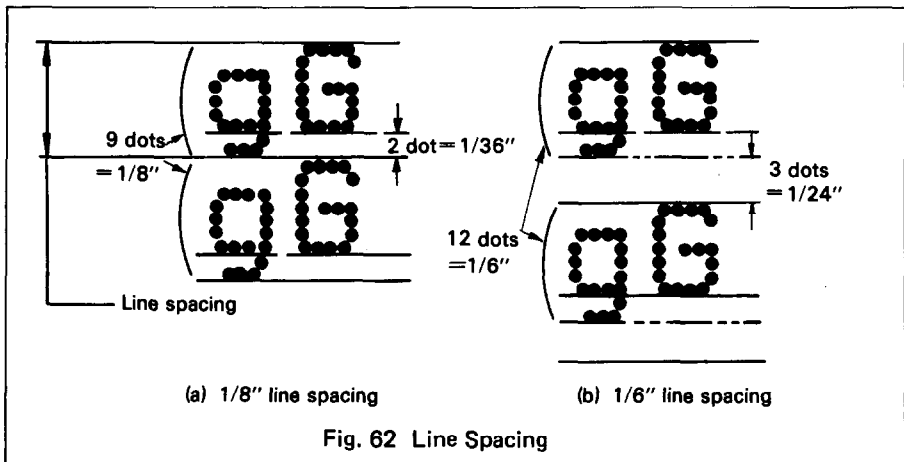

2. Definitions of Some Terms Often Used

Before looking at the printer in detail, some terms should be defined first so that you can understand them more easily and in less time.

They are:

- ASCII code
- Escape codes
- "+" symbol
- 2, D and H

If you are already familiar with the above terms, skip these paragraphs.

(1) ASCII code

Characters in computer systems are represented by groups of bits. The various groups of bits that represent the set of characters that are the “alphabet” of any given system are called a “coding system,” or simply “code.”

Codes for representing the information vary in relation to both the number of bits used to define a single character in the assignment of bit patterns to each particular character.

In US ASCII (The United States of America Standard Code for Information Interchange) code the bit group $(01000001)_2 = <41>_H$ represents the character “A”.

The sending and receiving equipment must be programmed to acknowledge the code used in computer systems.

The MX-80 Type II has 96 character set and control codes. In addition, it has an international character set as shown in a previous chapter. Those characters are put in some addresses of the ASCII code table instead of the standard characters. And those can be accessed by a particular control code or the DIP switch.

Alphabets, numbers and special symbols are addressed from $<20>_H$ to $<7E>_H$ and from $<A0>_H$ to $<FE>_H$. So same characters are put in two different addresses. The selection of which one to use is up to you if your machine has an 8-bit data bus line.

(2) Escape codes

In a lot of control codes that the MX-80 Type II has, you might be confused by the word “ESCAPE”.

Some alphabetical letters and some numbers follow it. Each of them causes a special function to the printer, i.e.

- (a) To format a sentence.
- (b) To do emphasized printing.
- (c) To select paper end detector programmably.
- (d) To set column length.
- (e) To select an international character set.
- (f) Others.

Generally, printer control codes, especially like “ESCAPE,” are not standardized. Every computer and printer manufacturer applies its own meaning to such codes.

The “ESCAPE” codes used in the MX-80 Type I I should not be confused with the escape key which some computers have. So be familiar with EPSON's control codes.

(3) "+" symbol

You will see "+" symbol often in the explanation or description of control codes from now on.

This symbol is used for legibility only and may not be input in your actual program.

(4) 2, D (or Dec.) and H (or Hex.)

()₂, ()_D and < >_H respectively represent binary, decimal and hexadecimal numbers.

3. Control Codes in the Text Mode

With the MX-80 Type II, two standard operation modes are available. One is the Text Mode which prints corresponding characters on normal ASCII coded inputs and the other, the Bit Image Mode which permits printing of pictures and images in dot configurations. The Text Mode is described in this section while the Bit Image Mode is covered in the following section.

The MX-80 Type I I has been designed as a terminal unit capable of various software controls. When control codes are transferred to the Printer, respective functions governed by these codes such as form feed, line feed, etc. are executed immediately. In order to permit the Printer to fully exhibit these functions, careful reading and thorough understanding of the following control codes are recommended. In this section, first the control codes in text mode are classified into groups. These two modes are not fully independent of each other in that parameters set in the Text Mode are also effective in the Bit Image.

(1) Print action codes

- CR Carriage return
- LF Line feed
- VT Vertical tabulation
- FF Formfeed

(2) Paper formatting control codes

(a) Horizontally

- ESC D, HT Tabulation
- ESC Q Column length

(b) Vertically

- ESC B, VT. Tabulation
- ESC 0, ESC 2, ESC A Line spacing
- ESC C, FF Form length, form feed
- ESC N, ESC O Skip-over perforation

(3) Character designation codes

- SO, ESC SO, DC 4 Enlarged printing
- SI, ESC SI, DC 2 Condensed printing
- ESC E, ESC F Emphasized printing
- ESC R International character set

(4) Other codes

DC1, DC3...	Selection or deselection of the printer
ESC8. ESC9...	Selection or deselection of the paper end detector
BEL	Bell
BS	Back space
NUL	Null
ESC K, ESC L	Access code to Bit Image mode (described later).

3.1. Print action codes

(1) CR (Carriage Return)

When the CR code is transmitted to the print buffer, all data stored in the print buffer is printed. When AUTO FEED XT (Pin No. 14 of the interface connector) is at "LOW" level, the paper is advanced one line automatically after the execution of printing by the CR code.

- NOTES:**
- 1. When 80 columns of print data (including spaces) are continuously received and the following data is valid and printable, the Printer automatically begins to print the data stored in the print buffer. (In this case, if AUTO FEED XT is at "LOW" level, the paper is advanced one line after printing.)**
 - 2. If no data precedes the CR code, or if all preceding data is "SPACE," the carriage assembly does not operate. Under this condition, if AUTO FEED XT is at "LOW" level, only paper feeding is performed.**
 - 3. When all 80 columns of data are "SPACE," the carriage assembly does not operate. Under this condition, if AUTO FEED XT is at "LOW" level, or if the DIP switch pin 2-3 on the control circuit board is ON, only paper feeding is performed.**

(2) LF (Line Feed)

When the LF code is input, all data in the print buffer is printed and the paper is advanced one line.

NOTE: If no data precedes the LF code, or if all preceding data is "SPACE", only paper feeding is performed. For example, if the data is transferred in the order of DATA -> CR -> LF, DATA will be printed by the CR code, and when the Printer receives the LF code, it only carries out one line feed, because no print data precedes the LF code.

(3) VT (Vertical Tabulation)

When the VT code is input, all data preceding this code is printed and the vertical tabulation is made to a predetermined line position set by "ESC B" (up to 8 positions). If no vertical tab position is set by ESC B, the VT code behaves like the LF code. Therefore, the paper is advanced one line after printing.

(4) FF (Form Feed)

The FF code causes the Printer to execute the printing of all data stored in the print buffer and advances the paper to the next predetermined Top of Form position.

- NOTES: 1. The Top of Form is determined when the POWER switch is turned on or the INIT signal is applied.
2. If the form length per page is not set, one page length of form is regarded as 66 lines with the DIP switch pin 1-2 on the control circuit board set in the OFF position or 72 lines with the DIP switch pin 1-2 set in the ON position. (The amount of line spacing is governed by the DIP switch setting at that time. When power is applied, the amount of line spacing is set at 1/6 inch with the DIP switch 1-1 set in the OFF position or 1/8 inch with the DIP switch pin 1-1 set in the ON position.)
3. The form length can be set by ESC C + n or ESC C + <0>_h + m as described later.

3.2. Paper formatting codes

(1) **HT** (Horizontal Tabulation)

The HT code carries out the horizontal tabulation to a predetermined position set by "ESC D" (up to 12 positions). The tab setting exceeding the column length set by the DIP switch or ESC code will be ignored. In enlarged character mode, the tab setting will not be effective and will be ignored.

(2) ESC D + n₁ + n₂ + + n_k + NUL

$$(1 \leq (n)_D \leq 132, k \leq 12)$$

This code specifies the horizontal tab stop positions. "n" denotes column position where the print head stops. The first 12 tab stops per line are recognized in the Printer, and subsequent tab stops are ignored. The tab stop positions can be specified up to 80 columns in normal character mode and 132 columns in condensed character mode. The excess tab positions, if specified, will be ignored.

$$1 \leq n \leq 80 \quad \text{in normal character mode}$$

$$1 \leq n \leq 132 \quad \text{in condensed character mode}$$

In enlarged character mode, the tabulation is not effective. To execute tabulation, the HT code should be input.

The NUL code should be input as the command for the termination of the tab set sequence, and the lack of this code will cause incorrect data printout.

1. In case of 5th, 10th and 21st columns.

```
[DATA]  [ESC D] <5>H <A>H <15>H [NUL] ABC [HT] DEF [HT] GHI
        [HT] JKL [CR] [LF]
[PRINT]  ABC   DEF   GHI           JKL
```

2. In case of lack of stop position.

```
[DATA]  [ESC D] <5>H <A>H [NUL] ABC [HT] DEF [HT] GHI [HT] JKL
        [CR] [LF]
[PRINT]  ABC   DEF   GHIJKL
```

3. In case of character data transferring over next tab stop.

```
[DATA]  [ESC D] <5>H <A>H <15>H [NUL] ABCDEF [HT] GHI [HT] JKL
        [CR] [LF]
[PRINT]  ABCDEF   GHI           JKL
```

4. In case of transferring two HT codes at a time.

```
[DATA]  [ESC D] <5>H <A>H <15>H [NUL] ABCD [HT] [SPACE] [HT]
        EFGH [CR] [LF]
[PRINT]  ABCD           EFGH
```

(3) ESC Q + n

The print column width can be specified by inputting ESC Q + n code. "n" represents the print column width to be specified in character size at the time of input.

- | | |
|---------------------|------------------------------|
| $1 \leq n \leq 80$ | normal character |
| $1 \leq n \leq 132$ | condensed character |
| $1 \leq n \leq 40$ | enlarged character |
| $1 \leq n \leq 66$ | enlarged-condensed character |

(4) ESC A + n (for setting amount of line spacing)

This code specifies the amount of line spacing in the Line Feed, provided that (n)_D must satisfy the condition: $1 \leq (n)_D \leq 85$ (Decimal).

"n" = 1 is equivalent to 1/72 inch paper advancement. Since the distance between any two dot wires of the print head is 1/72 inch, any line spacing in increments proportional to the distance between the dot wires can be established.

NOTES: 1. When the POWER switch is turned on or INIT signal is applied to the pin No. 31 of the interface connector, the line spacing is set at either 1/8 inch or 1/6 inch according to the ON/OFF position of the DIP switch pin 1-1 on the control circuit board.

2. The ESC A + n code may be input at any position on a line. However, once the code is input, the specified amount of line spacing will remain unchanged until a code for new line spacing is set.

(Example) To specify the amount of line spacing at 7/72 inches.

[DATA]	ESC A + 7	A A A A A A A A A A	CR	LF
		A A A A A A A A A A	CR	LF
		A A A A A A A A A A	CR	LF
[PRINT)		AAAAAAAAAAAAAAAA		
		AAAAAAAAAAAAAAAA		
		AAAAAAAAAAAAAAAA		

NOTE: <How to input "n">

When "n" is actually transferred to the Printer as data, it is transferred in the form of a 7-bit binary number.

In case of "ESC A + 24" to specify the amount of line spacing at 24/72 = 1/3 inch (24 = (00011000)), actual output to the Printer is performed as <1B>, <41>, <18>, in hexadecimal code.

Keep in mind that the method of input from the keyboard of a host computer is different, for which refer to the specifications of your host computer.

• Example: Input from the keyboard of the TRS-80 personal computer.

[LPRINT CHR\$(27); CHR\$(65); CHR\$(24)]

(5) ESC 0

Input of the ESC 0 causes the subsequent line spacing to be set at 1/8 inch.

(6) ESC 2

Input of the ESC 2 causes the subsequent line spacing to be set at either 1/6 inch or 1/8 inch depending on the initial set condition of the DIP switch pin 1-1.

(7) VT (Vertical Tabulation)

See paragraph 3.1 (3) above.

(8) ESC B + n₁+ n₂+ . . . +n_k+ NUL

(1 ≤ k ≤ 8, n_k ≤ n_{k+1})

This code specifies the vertical tab stop positions.

The first 8 valid tab stops per page are recognized in the Printer; subsequent tab stops are ignored.

A tab stop set at a line exceeding the form length specified by ESC C + n is ignored. If the form length is set to 66 lines upon initial power application, the last tab stop (n_k)_s should be less than 66.

Tab stop numbers must be received in incremental numerical order. (n_k ≤ n_{k+1})

To execute tabulation, the VT code should be input. Once vertical tab stops are established, the data will be valid until new tab stops are specified. If no tab stop is set, the VT code behaves like the LF code. Therefore, the paper is advanced one line after printing.

Receipt of "ESC B" code causes the Printer to accept the following codes as tab stop line numbers until the NUL code is input. The lack of the NUL code will cause incorrect data printout.

The form length must be set by "ESC C + n" or "ESC C + 0 + m" code prior to setting tab stops. The VT setting is cancelled by input of "ESC C + n" code. Therefore, the tab setting should then be established again. Input of "ESC B" code followed by only the NUL code cancels predetermined tab stops.

[DATA]	ESC B	<4> _H	<6> _H	<A> _H	NUL	
	AAAAAAA	VT	BBBBBBB	VT	CCCCCCC	VT DDDDDDD

[PRINT] AAAAAAA 1st line

BBBBBBB 4th lines

CCCCCCC 6th lines

DDDDDDD 10th lines

(9) FF (Form Feed)

See paragraph 3.1 (4) above.

(10) ESC C + n (n ≠ 0), ESC C + [0]_H+ m (for setting form length)

The "ESC C t n" code specifies the form length which is determined by the number of lines (n: $1 \leq (n)_D \leq 127$ where the value of "n" is a positive number and must not exceed 127 lines). In other words, the maximum form length is 127 lines. The amount of line spacing when this code is input is a predetermined numerical value by ESC A + n. When the form length is not programmed by the ESC C + n code, one page is assumed as 66 lines with the DIP switch pin 1-2 on the control circuit board set in the OFF position, or 72 lines with the DIP switch pin 1-2 set in the ON position.

The "ESC C + [0]_H+ m" code specifies the absolute quantity of form length in * units of inches ($1 \leq (m)_D \leq 22$). Therefore, even if the amount of line spacing is changed on the page, the absolute quantity of form length remains unchanged. "m" denotes the form length in inches.

NOTES: 1. With the ESC C + n code, the form length can be defined by the number of lines using the amount of line spacing set by the ESC A + n code. With the ESC C + [0]_H+ m code, the form length can be defined as an absolute quantity in unit of inches.

2. Input of "ESC C" code cancels the VT set by "ESC B" and the skip-over perforation set by "ESC N."

3. <0>_H denotes hexadecimal "00."

(11) ESC N + n (n ≠ 0) (for setting skip-over perforation)

The ESC N + n code is used to set the skip-over perforation function, which specifies the number of lines "n" to be skipped at the bottom of a page (n: $1 \leq (n)_D \leq 127$ where the value of n is a positive number).

For example, if the last three lines of a page is to be skipped, the value of n must be entered as "3." Note that the value of n cannot be set greater than the form length specified by the ESC C + n code.

When the current form length is changed by the input of the ESC C + n or ESC C + <0>_H+ m code again, the amount of skip-over perforation previously set is cancelled. In this case, therefore, the ESC N + n code must be input again to set the amount of skip-over perforation. When the amount of skip-over perforation is not set by the ESC N + n code or the DIP switch pin 2-4 on the control circuit board is OFF, skip-over perforation for 1 inch is executed.

(Example) 3-line skip-over perforation

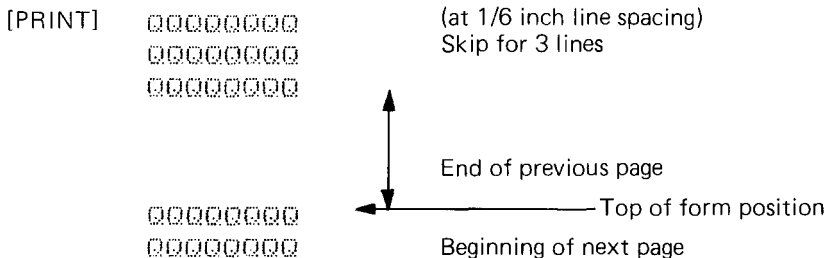

(12) ESC 0

This code cancels the skip-over perforation set by the ESC N + n code.

3.3. Character designation codes

(1) SO (Shift Out) (for enlarged characters)

When the SO code is input, all data that follows it in the same line will be printed out in enlarged (double width) characters. This code is cancelled by the printing operation or the input of "DC 4" code and can be input at any column position on a line. Therefore, normal size and enlarged characters can be mixed on the same line.

NOTE: With normal size and enlarged characters mixed on the same line, when any enlarged character is at the 79th column position in terms of normal size character, this position becomes the end position of the line (i.e., "Print Buffer Full" position).

1. [DATA] ABC [SO] DEF [DC 4] GHI [CR] [LF]

[PRINT] **ABCDEF** GHI

2. [DATA] ABCD [SO] EFGH [CR] [LF] IJKL [SO] MNOP [CR] [LF]

[PRINT] **ABCDEF** GH
IJKLMNOP

(2) SI (Shift In) (for condensed characters)

When the SI code is input, all data that follows it will be printed out in condensed characters. This code is cancelled by the input of "DC 2" code. The SI code can be input at any column position on a line, but all characters/symbols on the line containing SI code are printed out in condensed characters. Normal and condensed characters cannot be mixed on the same line.

When printing condensed characters, the data capacity of the print buffer will become 132 columns per line (in terms of condensed size character). When the SO code is received after the input of the SI code, condensed enlarged characters (double width of condensed characters) can be printed. This condition is cancelled by "DC 4" code or LF code, and the character size returns to "condensed."

1. [DATA]	<input type="checkbox"/> SI	ABCDEF	GHIJKL	<input type="checkbox"/> CR	<input type="checkbox"/> LF		
[PRINT]		ABCDEF	GHIJKL				
2. [DATA]	ABC	<input type="checkbox"/> SI	DEF	<input type="checkbox"/> SO	GHIJKL	<input type="checkbox"/> CR	<input type="checkbox"/> LF
[PRINT]	ABCDEF	GHI	IJKL				

(3) ESC SO

This code functions the same as the SO code.

(4) ESC SI

This code functions the same as the SI code.

(5) DC 4 (Device Control 4)

The DC 4 code cancels the SO mode (enlarged character printing function).

[DATA]	<input type="checkbox"/> SI	ABCDEF	<input type="checkbox"/> SO	GHI	<input type="checkbox"/> DC 4	JKL	<input type="checkbox"/> CR	<input type="checkbox"/> LF
[PRINT]		ABCDEF	GHI	IJKL				

(6) DC 2 (Device Control 2)

The DC 2 code cancels the SI mode (condensed character printing function).

NOTE: The SO mode can be cancelled by the DC 4 code or LF code, but the SI mode can be cancelled by the DC 2 code alone.

[DATA]	<input type="checkbox"/> SI	ABCDEF	<input type="checkbox"/> SO	GHI	<input type="checkbox"/> CR	<input type="checkbox"/> LF	<input type="checkbox"/> DC 2	JKLMN	<input type="checkbox"/> CR	<input type="checkbox"/> LF
[PRINT]		ABCDEF	GHI	JKLMN						

(7) ESC E (for emphasized characters)

The ESC E code causes the Printer to print emphasized characters.

Emphasized printing gives the character a stronger impression on the paper.

This code can be input in any column position on a line, but all characters on the line containing ESC E code are printed out in emphasized characters. The speed of the head carriage reduces to 40 CPS while printing emphasized characters.

1. [DATA]	<code>ESC E</code>	ABCDEFGHI	<code>CR</code>	<code>LF</code>
[PRINT]		ABCDEFGHI		
2. [DATA]	<code>SO</code>	<code>ESC E</code>	ABCDEFGHI	<code>CR</code> <code>LF</code>
[PRINT]		ABCDEFGHI		

(8) ESC F

The ESC F code cancels the emphasized printing mode.

(9) ESC R + n (for international character set)

($0 \leq n \leq 7$)

When the "ESC R + n" code is input, all data that follows it will be printed out in a country character set which is specified by "n." It will be valid until specified by other "ESC R + n" code.

"n" represents one of the following country character sets.

n	Country
0	U.S.A.
1	France
2	Germany
3	England
4	Denmark
5	Sweden
6	Italy
7	Spain

As for specific code tables and character fonts, refer to Appendixes 3 and 4.

3.4. Other codes

(1) DC 1 (Device Control 1)

The DC 1 code places the Printer in the Selected state. It enables the Printer to receive data.

With the Printer in the Selected state, if the DC 1 code is input during data transfer, all data stored before the DC 1 code is ignored.

(2) DC 3 (Device Control 3)

The DC 3 code places the Printer in the Deselected state. In other words, it disables the Printer to receive data. Once the Printer is put in the Deselected state by the DC 3 code, the Printer will not revert to the Selected state unless the DC 1 code is input again.

NOTE: When the DC 1 and DC 3 codes are used, the DIP switch pin 1-8 on the control circuit board should be in the "OFF" position.

1. [DATA]	<input type="checkbox"/> DC 1	AAAAA	<input type="checkbox"/> DC 3	BBBBB	<input type="checkbox"/> DC 1	CCCCC	<input type="checkbox"/> CR	<input type="checkbox"/> LF
[PRINT]	AAAAACCCCC							
2. [DATA]	AAAAA	<input type="checkbox"/> DC 1	BBBBB	<input type="checkbox"/> DC 3	CCCCC	<input type="checkbox"/> DC 1	<input type="checkbox"/> CR	<input type="checkbox"/> LF
[PRINT]	BBBBB							

(3) ESC 8 (Escape 8) (to ignore the Paper End detector)

The ESC 8 code makes it possible to transmit data even if there is no paper in the Printer. Since this code causes the PE signal to be ignored, data may be printed to the last page of the form without waste of paper. With the DIP switch pin I-6 on the control circuit board set in the ON position, the Printer is placed in the ESC 8 condition upon application of power.

(4) ESC 9 (Escape 9)

This code cancels the ESC 8 condition, and reinstates the PE signal. Therefore, the Printer cannot receive data when there is no paper. With the DIP switch pin I-6 set in the OFF position, the Printer is placed in the ESC 9 condition upon application of power.

(5) **BEL** (Bell)

When the BE L code is input, the buzzer sounds for about 1 second.

Arbitrary use of this code is recommended to arouse the attention of the operator.

(6) BS (Back Space)

The BS code cancels the data immediately preceding this code in the Text Mode. In other words, one byte data stored prior to the BS code is cleared from the print buffer, as though that data has not been transferred from the host computer. Note that this code is valid only in the Text Mode.

(7) NUL (Null)

The NUL code is regarded as the termination for tabulation setting sequence. The lack of the NUL code would cause incorrect data printout.

(8) ESC K

Input of this code in the Text Mode causes the Printer's operation mode to be converted from Text to Normal-density Bit Image. Refer to paragraph 4.1, section 4, for details.

(9) ESC L

Input of this code in the Text Mode causes the Printer to perform dual-density bit image printing. Refer to paragraph 4.2, section 4, for details.

4. Control Codes in the Bit Image Mode

Most of the abovementioned control codes are normally used in the text mode. Control codes associated with the Bit Image mode will be discussed next. Each computer has its unique way of handling graphics.

For example, in the CBM computer there is a set of 64 special graphic characters that can be used to draw and plot with. On the other hand, the APPLE II computer has no graphic characters but a rich variety of graphic statements that allow you to control any dot in a 280-by-193 screen matrix. As well as the latter "APPLE II," the MX-80 Type II has no character generated graphics but allow you to control all the 8 needles freely and programmably by means of the so-called "Bit Image".

To do that you have to switch the printer from the text mode to the bit image mode by inputting an escape code. This bit image mode expands the ability of the printer.

The printer enters bit image mode when ESC K or ESC L code is input, and utilizes a raster scan technique that enables the printing of vertical columns of 8 dots across a page during each pass of the print head. To receive bit image data, RAM (128 bytes) of an IC on the control circuit board is used exclusively. When the bit image data received by the printer exceeds the RAM capacity, the printer will start printing bit image data from the first-in data, so that the RAM may always be filled up with data up to its capacity of 128 bytes.

4.1. Normal-density bit image mode setting by ESC K + n₁+ n₂

To convert the printer's operation mode from Text to Normal-density Bit Image, the "ESC K + n₁+ n₂" code must be input. (Here, the sign "+" is inserted for the purpose of legibility only and should not be input in actual operation.) Namely, when ESC (<1B>_n) and K (<4B>_n) codes and data n₁ and n₂ are input, the Printer recognizes the data following the "ESC K" as the bit image data. n₁ and n₂ are the hexadecimal numbers each consisting of 2 digits which define the amount of the bit image data to be transferred.

n₁ represents the low-order two digits while n₂ represents the high-order two digits. In the normal-density bit image processing, the maximum number of dot positions printable per line is 480. Therefore, the values of n₁ and n₂ specified in excess of 480 dot positions are ignored and printing of the bit image data after the 480th dot position is not guaranteed.

Mixing of text data and bit image data is possible on the same line.

NOTE: Assign values to n₁ and n₂, respectively as follows.

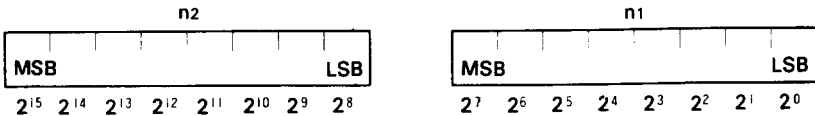

As shown above, n₁ is set hexadecimally as low-order bytes and n₂ as high-order bytes.

(Ex. 1) Input data

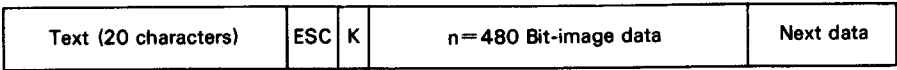

20 characters in text mode correspond to 120 bit-image positions (20 x 6 = 120). So the remaining printable positions in Bit-image mode are 360 (480 - 120 = 360). If 480 data are input as bit-image mode characters, the first 360 data can be printed but the remaining 120 data are ignored and thus not printed.

(Ex. 2) Input data

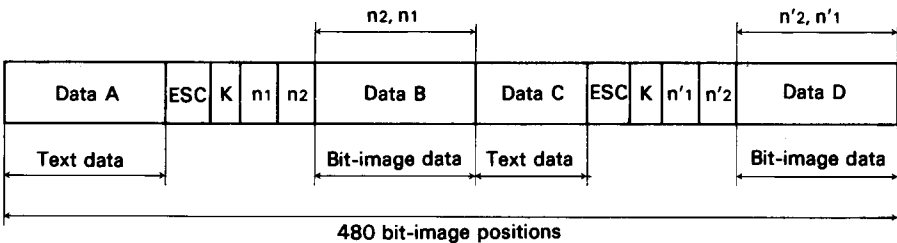

Printing

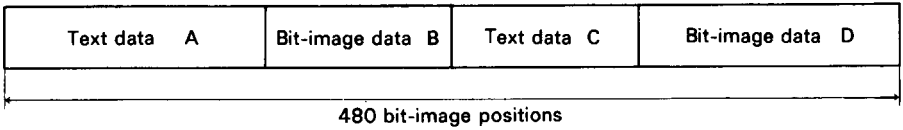

(Ex. 3) Input data

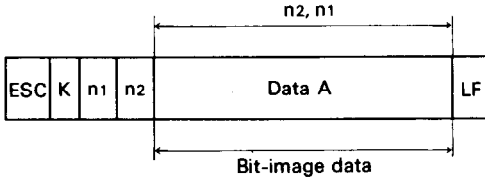

Printing

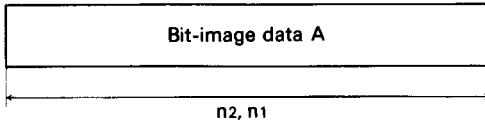

(Ex. 4) Bit image data transfer by standard BASIC program

To check for proper conversion to the Normaldensity Bit Image mode, execute the following program.

[PROGRAM]

```
150 REM bit image printing
160 LPRINT CHR$ ($H1B); "K"; CHR$ ($H50); CHR$ (&H0);
170 FOR N=1 TO $H50
180 LPRINT CHR$(&HFF);
190 NEXT
200 LPRINT CHR$ ($HA);
210 GO TO 160
```

[PRINT]

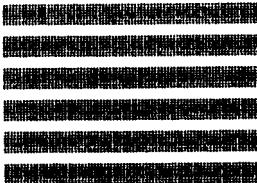

4.2. Dual-density bit image mode setting by ESC L + n₁ + n₂

When the ESC (<1B>,) and L (<4C>,) codes followed by data n₁ and n₂ are input, the printer's operation mode is converted from Text to Dual-density Bit Image.

The transfer sequence of bit image data is the same as with the ESC K (normal-density bit image printing), but bit image printing can be performed in twice the dot density in the horizontal direction as with the ESC K. In other words, bit image data can be printed in 960 dot positions per line, thus permitting to produce denser graphic data.

[PROGRAM]

```
150 REM bit image printing (DUAL DENSITY)
160 LPRINT CHR$(&H1B); "L"; CHR$(&H50); CHR$(&H0);
170 FOR N=1 TO &H50
180 LPRINT CHR$(&HFF);
190 NEXT
200 LPRINT CHR$(&HA);
210 GO TO 160
```

[PRINT]



NOTE: Mixing of normal-density bit image with dual-density bit image on a line is at your option, as well as mixing with normal size characters in the text mode.

4.3. Relationship between data and dot wires

Fig. 68 shows the relationship between the Bit Image data and the dot wires in the print head. You can control arbitrary 8 dot wires in the print head.

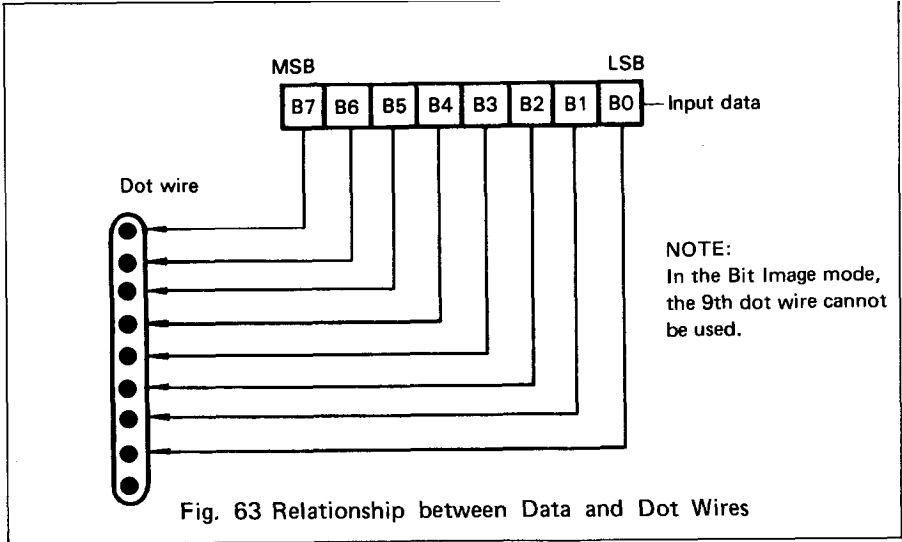

If a bit is "1," the print head fires. If a bit is "0," the print head does not fire. For example, assume that data are given as follows;

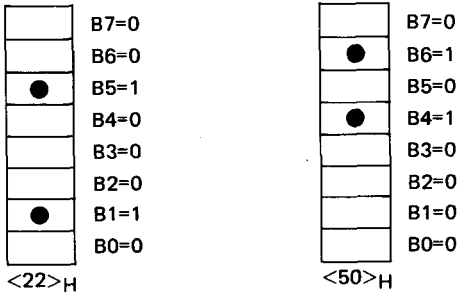

where a box with "●" denotes the bit "1" and a blank box denotes the bit "0." According to Appendix 3, Code Table, you can define (00100010)₂ as <22>_H and (01010000)₂ as <50>_H.

As you can see the first 4 bits are defined from column and the second 4 bits are defined from row. Namely,

(0101)₂ = <5>_H, and (0600)₂ = <0>_H.

4.4 How to obtain n_1 and n_2

In the Type II Printer, you have send the number of data by $n_1 + n_2$ in hexadecimal numbers following the ESK K or ESC L. If the number of bit image data is 300, then n_1 and n_2 may be derived as follows;

$$\begin{aligned}n_1 &= (\text{Number of data}) \text{ MOD } 256 \\ &= 300 \text{ MOD } 256 \\ &= (44)_D \\ &= \langle 2C \rangle_H\end{aligned}$$

$$\begin{aligned}n_2 &= \text{INT} (\text{Number of data}/256) \\ &= \text{INT} (300/256) \\ &= (1)_D \\ &= \langle 01 \rangle_H\end{aligned}$$

You can also use Appendix 3, Code Table, to find the corresponding hexadecimal numbers to the decimal numbers. The schematic of data transfer sequence in the Bit Image mode is shown in Fig. 64.

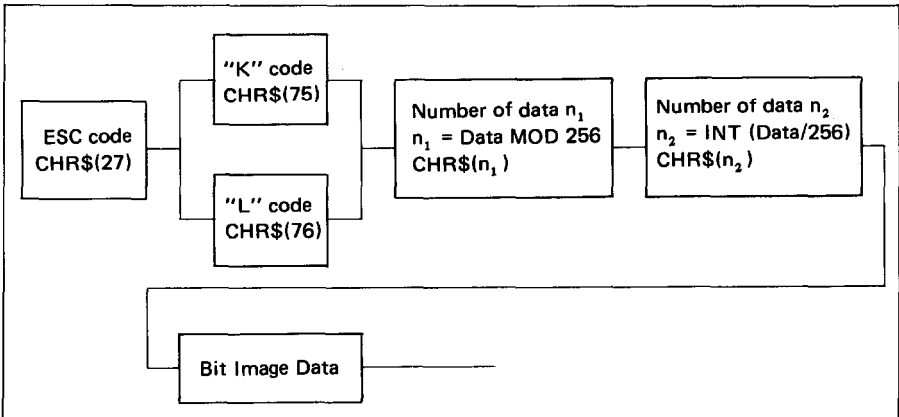

Fig. 64 Data Transfer Sequence in Bit Image Mode

4.5. Programming examples

(1) Dual-density bit image printing

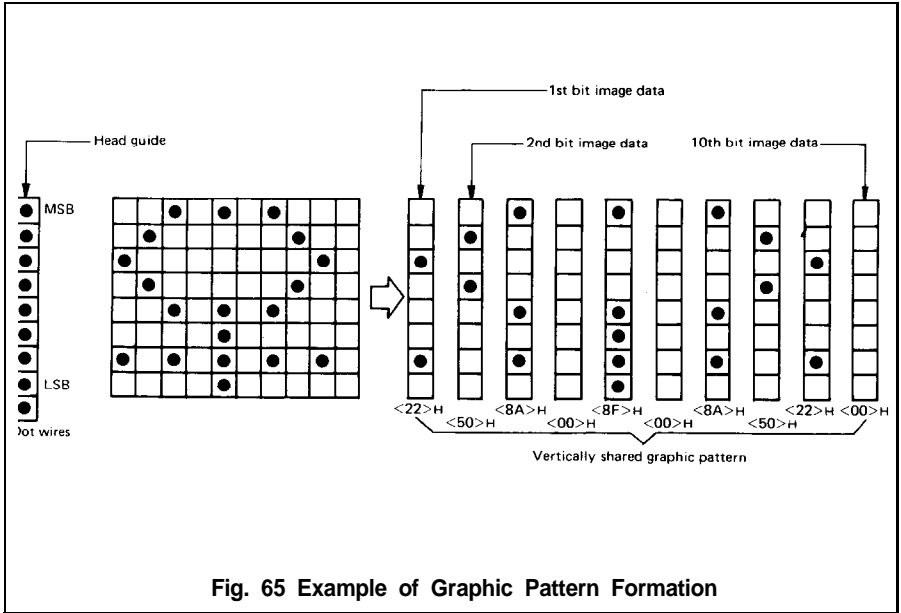

Fig. 65 Example of Graphic Pattern Formation

NOTE: The most significant bit (MSB) of the bit image data corresponds to the dot wire at the uppermost position.

For example, to print a graphic data as shown in Fig. 65, a program such as shown below must be executed. However, this program has been developed using standard BASIC language. If extended BASIC is to be used, the program must be changed according to the features of the language.

In addition, if data is to be transferred through an interpreter of BASIC, etc., the data transfer rate is extremely slow. In such a case, it is recommended to effect the data transfer through machine language, etc.

[PROGRAM]

```
10 REM BIT IMAGE PRINTING (DUAL DENSITY)
20 LPRINT CHR$(27); "L"; CHR$(10); CHR$(0);
30 FOR N=1 TO 10
40 READ R
50 LPRINT CHR$(R);
60 NEXT
70 LPRINT
80 DATA &H22, &H50, &H8a, &h00, &HBf, &h00, &h8a,
    &h50, &h22, &h00
90 END
```

[PRINT]

♀

(2) Normal-density bit image printing

[PROGRAM]

```
10 REM BIT IMAGE PRINTING (NORMAL DENSITY)
20 LPRINT CHR$(27); "K"; CHR$(12); CHR$(0);
30 FOR N=1 TO 12
40 READ R
50 LPRINT CHR$(R);
60 NEXT
70 LPRINT
80 DATA &H04, &H0a, &H1a, &h3a, &H67, &he7
90 DATA &He7, &H67, &h3a, &h1a, &H0a, &h04
100 END
```

[PRINT]

♂

(3) Difference between ESC K and ESC L

The normal-density mode is accessed with ESC K. The dual-density mode is accessed with ESC L.

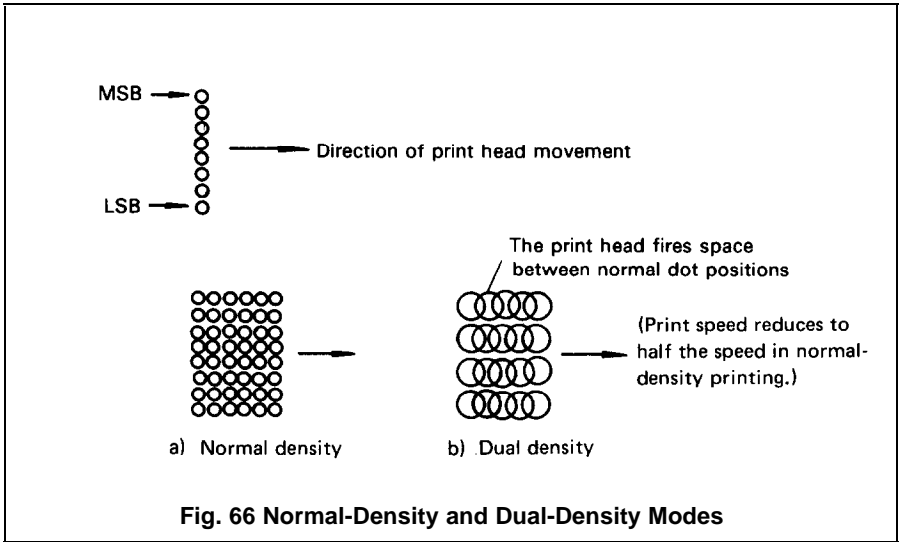

NOTE: Print alignment under the friction feed.

EPSON is carefully applying printer mechanisms of better quality for MX-80 Type II and MX-80 F/T Type II. However, due to the nature of friction feed in which paper may slip, it is not available to use the bit image mode while feeding the cut sheet or the roll paper in the MX-80 F/T Type I. If the accuracy of line feed is critical, the fanfold paper must be used.

(4) Example of CRT screen dump hard copy

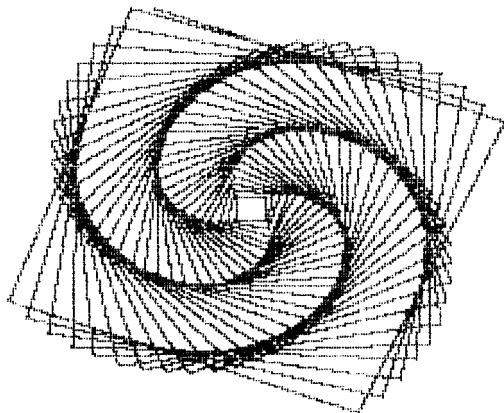

This print example is made using APPLE II computer and the demonstration diskette.

Fig. 67 Examples of Bit Image Printing

(5) Example of expression of brightness using the Bit Image Mode

(Ex.) Expression of brightness using the bit image mode

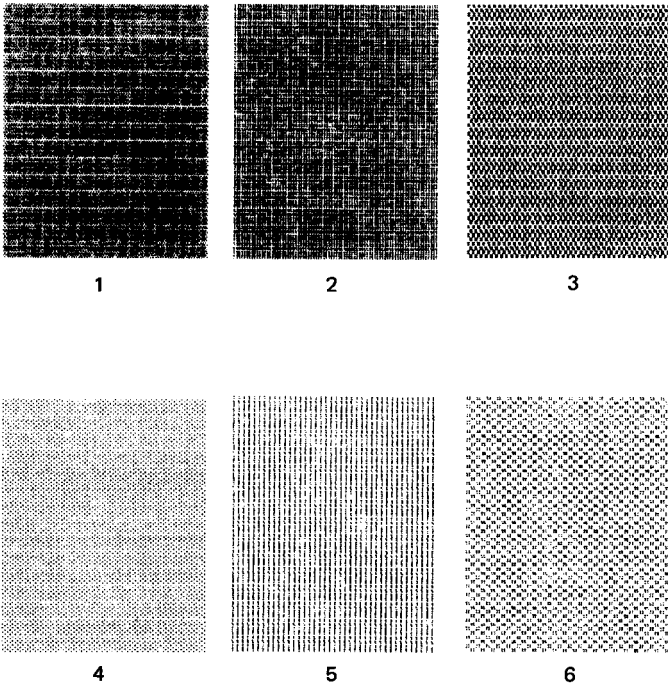

(Ex.) Expression of dot density

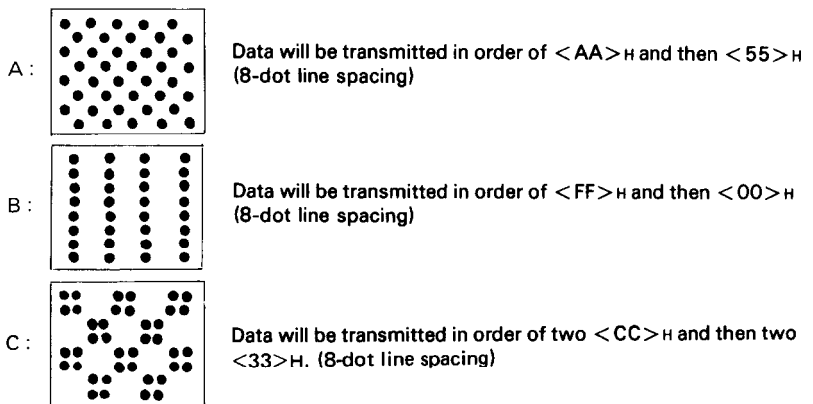

Fig. 68 Examples of Expression of Brightness

MAINTENANCE

1. Preventive Maintenance

Preventive maintenance for the MX-80 Type II and MX-80 F/T Type I I (hereafter referred to as "Type II Printer") consists basically of cleaning. The Printer should be cleaned with a soft brush to remove paper dust and particles after every three months of use. The exterior surface of the Printer can be cleaned by using a mild detergent and water solution.

2. Parts Replacement

(1) General

Owing to the sophisticated nature of the circuitry and mechanisms utilized in the Type II Printer, operator's troubleshooting is logically obliged to be limited to certain easily recognizable symptoms and cures. If a Printer malfunction other than the print head unit should occur the operator should contact the store from which the Type I I Printer was purchased.

(2) Print head

In case of a print head trouble or a worn dot wire, replace the print head unit as described below. (See Fig. 69.)

NOTE: Be sure to replace the print head after it has cooled.

STEP 1. Turn the power off.

STEP 2. Take off the printer lid and cartridge ribbon.

STEP 3. Turn the head lock lever clockwise and remove the print head.

STEP 4. Pull the head cable out straight while steadying the head connector on the terminal board.

STEP 5. Put a new head on the carriage assembly and replace the head lock lever.

STEP 6. Insert the head cable into the head connector carefully.

NOTES: 1. Inadequate connection may cause malfunctioning of the head.

2. The carriage assembly should not be moved without the print head mounted on the carriage.

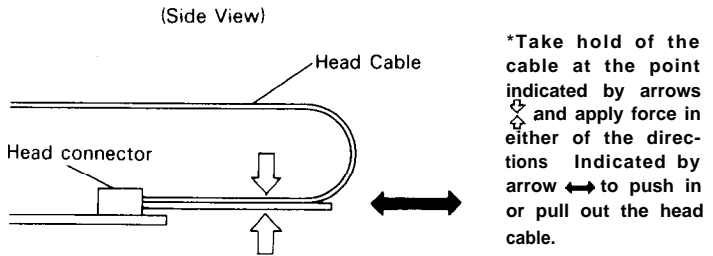
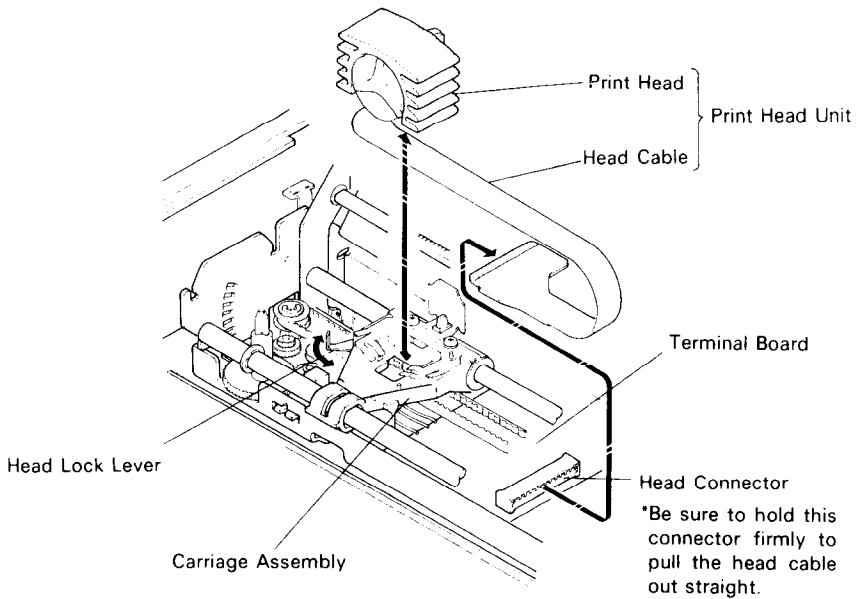

Fig. 69 Replacement of Print Head

SPECIFICATIONS

- (1) PRINT METHOD: Serial impact dot matrix
- (2) PRINT SPEED: 80 CPS
- (3) PRINT DIRECTION: Bidirectional with logical seeking
Unidirectional in the bit image mode
- (4) NUMBER OF PINS
IN HEAD: 9
- (5) LINE SPACING: 4.23 mm (1/6") or 3.18 mm (1/8")
selectable by DIP SW, or
1/72" to 85/72" programmable
- (6) PRINTING CHARACTERISTICS
- Matrix: 9 x 9
- Character Set: Full 96-character ASCII with descenders, plus
8 international character sets
- (7) PRINTING SIZES Selectable by DIP SW or programmable

	Characters per inch	Maximum characters per line
Normal:	10	80
Enlarged:	5	40
Condensed:	16.5	1 3 2
Condensed Enlarged :	8.25	66

(8) MEDIA HANDLING

- Paper Feed : Adjustable sprocket pin feed (and/or friction
feed for MX-80 F/T TYPE II)
- Paper Width Range MX-80 Type II MX-80 F/T Type II
- Fanfold paper: 4" to 10" 4" to 10"
(101.6 mm to 254 mm) (101.6 mm to 254 mm)
- Roll paper: 8.5" ± 0.12"
(215.9 ± 3 mm)
- Cut paper sheet: 8.3" to 8.5"
(210 mm to 216 mm)
- Copies: One original plus two carbon copies (total
thickness not to exceed 0.3 mm (0.012"))
- Paper Path: Rear

(9) INTERFACES

- Standard: Centronics-style 8-bit Parallel
- Optional: RS232C, IEEE 488, etc.

(10) INKED RIBBON

- Color: Black
- Type: Exclusive cartridge
- Life Expectancy: 3 million characters

SPECIFICATIONS (continued)

(11) MCBF: 5 x 10⁶ lines (excluding print head)

(12) ENVIRONMENTAL CONDITIONS

Operating Temperature Range:

5 to 35°C (41 to 95°F)

Operating Humidity: 10 to 80% non-condensing

(13) POWER REQUIREMENT

Voltage: 115v, 60Hz

220/240V, 50Hz

Current: 1 Amp maximum

Power Consumption: 100 VA maximum

(14) PHYSICAL CHARACTERISTICS

	MX-80 TYPE II	MX-80 F/T TYPE II
Height:	107 mm (4.2")	133 mm (5.2")
Width :	374 mm (14.7")	374 mm (14.7")
Depth:	305 mm (12.0")	305 mm (12.0")
Weight:	5.5 kg (12 lbs.)	7.0 kg (15.4 lbs.)

Specifications subject to change without notice.

APPENDIX 1

Construction of MX-80 Type II and MX-80 F/T Type II

The EPSON MX-80 Type II and MX-80 F/T Type II dot matrix printers (hereinafter referred to as "Type II Printer") consist of the following three major functional blocks.

- (1) Printer Mechanism
- (2) Control Circuit Board
- (3) Power Circuit

These three blocks are housed in a plastic case and are connected to one another.

1.1. Printer mechanism

The printer mechanism has been developed by EPSON Shinshu Seiki Co., Ltd., with the latest technology in the precision and electronic industry fields.

The printer mechanism contains two stepper motors. One is to move the print head to the next print column position, and the other is to advance the paper.

- (1) Stepper motor for head carriage

The stepper motor for head carriage is controlled under LSI "8041" called "slave CPU". The CPU knows the current printing position at any given time and the print head is stopped at the last printing position. Then, the CPU seeks the shortest travel way to the next print line.

This feature and bidirectional printing enable the Printer to perform the logical seeking function which minimizes the head travel time to the next print line.

- (2) Stepper motor for paper feed

Paper is fed by the stepper motor, like the head carriage. One complete rotation of the stepper motor corresponds to 1/3 inch paper advance. In the Type II Printer, the operator can select any paper feed length under software control.

- (3) Print head

The print head has 9 dot wires to form 9 x 9 dot matrix characters.

9 wires form more legible characters than those formed by 7 wires. The print head for the printer mechanism is quite compact.

1.2. Control circuit board

In this paragraph, the printer LSI circuitry is outlined. The control circuit diagram is shown in Fig. AI-1, and the driver circuit diagram in Fig. AI-2.

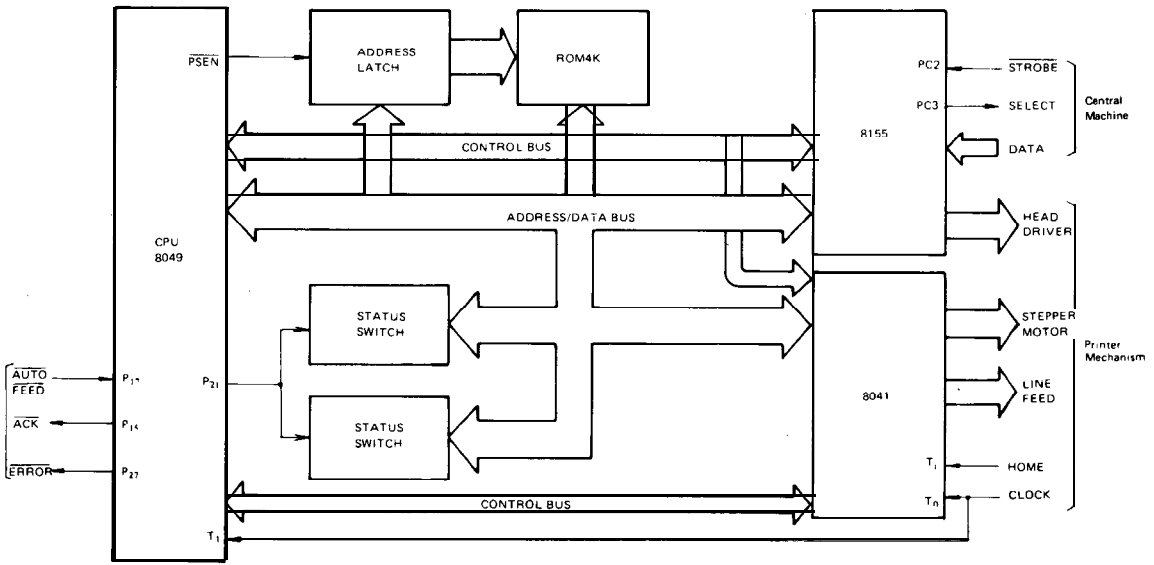

Fig. A1-1 Control Circuit Diagram

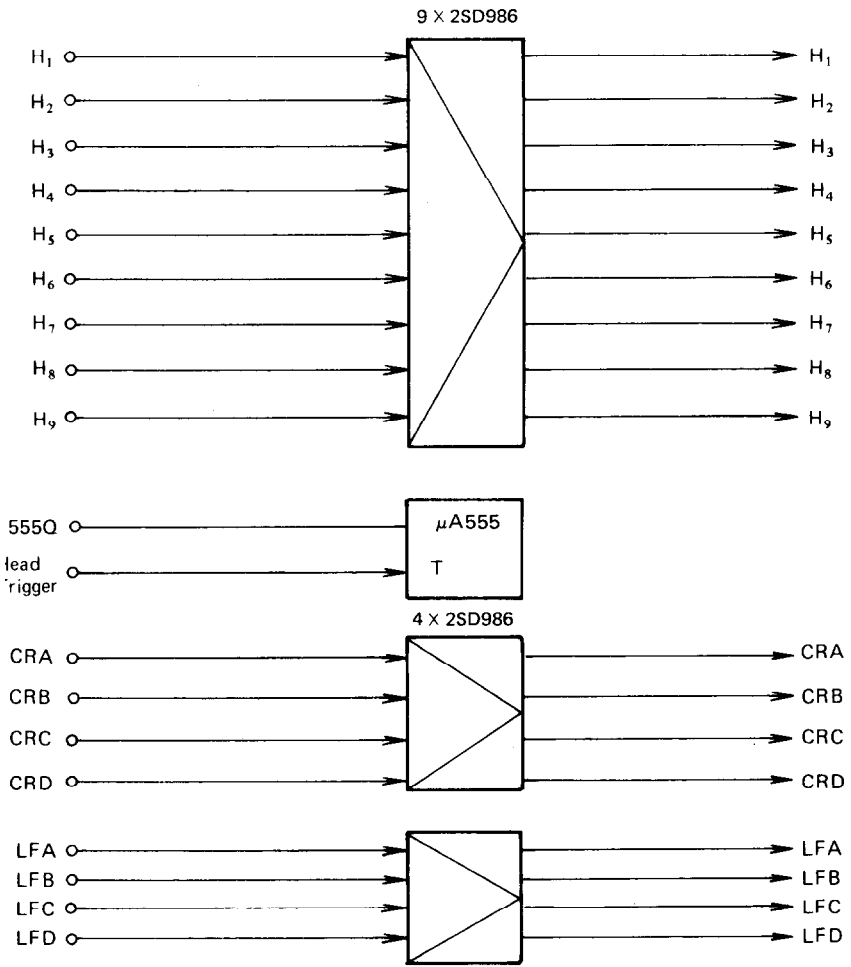

Fig. AI-2 Driver Circuit Diagram

1.3. Power circuit

The power circuit generates 5V DC for the logic circuit, and 24V DC to energize the solenoids of the print head and two stepper motors.

1.4. Printer initialization

Printer initialization is accomplished in either of the two ways described below.

- (1) Initialization takes place automatically each time the primary AC power source is interrupted and reapplied (i.e., by turning the Power Switch off and on).
- (2) Initialization may be initiated remotely by activating the INIT signal to the parallel interface connector. This line should be driven by a TTL driver or its equivalent.

APPENDIX 2 Parallel Interface

Both the MX-80 Type II and MX-80 F/T Type II include a parallel interface as the standard equipment, and this paragraph describes the parallel interface.

(1) Specifications

- (a) Data transfer rate: 1000 CPS (min.)
- (b) Synchronization: By externally supplied STROBE pulses.
- (c) Handshaking: By ACKN LG or BUSY signals.
- (d) Logic level: Input data and all interface control signals are compatible with the TTL level.

(2) Connector

Plug: 57-30360 (AMPHENOL)

It is recommended that interface cables be kept as short as possible.

(3) Connector pin assignment and descriptions of signals.

Connector pin assignment and descriptions of respective interface signals are provided in Table A2-1.

Table A2-1 Connector Pin Assignment and Descriptions of Interface Signals

Signal pin No.	Return pin No.	Signal	Direction	Description
1	19	<u>STROBE</u>	In	STROBE pulse to read data in. Pulse width must be more than 0.5 μ s at receiving terminal. The signal level is normally "HIGH"; read-in of data is performed at the "LOW" level of this signal.
2	20	DATA 1	In	These signals represent information of the 1st to 8th bits of parallel data respectively. Each signal is at "HIGH" level when data is logical "1" and "LOW" when logical "0".
3	21	DATA 2	In	
4	22	DATA 3	In	
5	23	DATA 4	In	
6	24	DATA 5	In	
7	25	DATA 6	In	
8	26	DATA 7	In	
9	27	DATA 8	In	
10	28	<u>ACKN LG</u>	Out	Approx. 5 μ s pulse. "LOW" indicates that data has been received and that the printer is ready to accept other data.
11	29	BUSY	Out	A "HIGH" signal indicates that the printer cannot receive data. The signal becomes "HIGH" in the following cases: 1. During data entry 2. During printing operation 3. In OFF-LINE state 4. During printer error status.
12	30	PE	Out	A "HIGH" signal indicates that the printer is out of paper.

Table A2-1 (cont'd)

Signal pin No.	Return pin No.	Signal	Direction	Description
13	—	SLCT	Out	This signal indicates that the printer is in the selected state.
14	—	$\overline{\text{AUTO FEED XT}}$	In	With this signal being at "LOW" level, the paper is automatically fed one line after printing. (The signal level can be fixed to "LOW" with DIP SW pin 2-3 provided on the control circuit board.)
15	—	NC		Not used.
16	—	0V		Logic GND level.
17	—	CHASSIS-GND	—	Printer chassis GND. In the printer, the chassis GND and the logic GND are isolated from each other.
18	—	NC	—	Not used.
19 to 30	—	GND	—	TWISTED-PAIR RETURN signal GND level.
31	—	$\overline{\text{INIT}}$	In	When the level of this signal becomes "LOW", the printer controller is reset to its initial state and the print buffer is cleared. This signal is normally at "HIGH" level, and its pulse width must be more than 50 μ s at the receiving terminal.
32		$\overline{\text{ERROR}}$	Out	The level of this signal becomes "LOW" when the printer is in - 1. PAPER END state 2. OFF-LINE state 3. Error state
33	—	GND	—	Same as with Pin Nos. 19 to 30.
34	—	NC	—	Not used.
35				Pulled UP to +5V through 3.3k Ω resistance.
36	—	$\overline{\text{SLCT IN}}$	In	Data entry to the printer is possible only when the level of this signal is "LOW". (Internal fixing can be carried out with DIP SW pin I-B. The condition at the time of shipment is set "LOW" for this signal.)

- NOTES:
- "Direction" refers to the direction of signal flow as viewed from the printer.
 - "Return" denotes "TWISTED PAIR RETURN" and is to be connected at signal ground level.
As to the wiring for the interface, be sure to use a twisted-pair cable for each signal and never fail to complete connection on the Return side. To prevent noise effectively, these cables should be shielded and connected to the chassis of the host computer and the printer, respectively.
 - All interface conditions are based on TTL level. Both the rise and fall times of each signal must be less than 0.2 μ s.
 - Data transfer must not be carried out by ignoring the $\overline{\text{ACKNLG}}$ or BUSY signal. (Data transfer to this printer can be carried out only after confirming the $\overline{\text{ACKNLG}}$ signal or when the level of the BUSY signal is "LOW".)

(4) Data transfer sequence

Fig. A2-1 shows the sequence for data transmission.

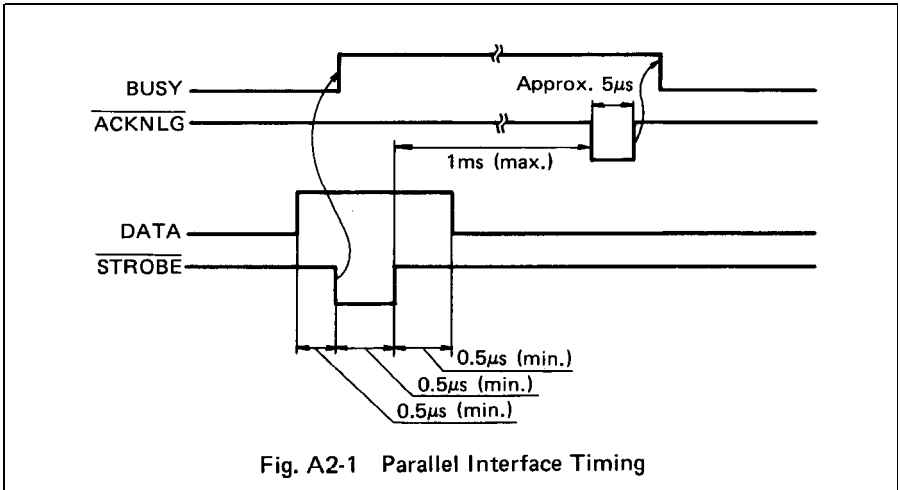

Fig. A2-1 Parallel Interface Timing

Relations among the ON LINE switch, $\overline{\text{SLCT IN}}$ signal, DC 1/DC 3 code and interface signals are shown in Table A2-2 below.

Table A2-2 Relations among ON-LINE, $\overline{\text{SLCT IN}}$, DC 1/DC 3 and Interface Signal

ON LINE SWITCH	$\overline{\text{SLCT IN}}$	DC 1/DC 3	$\overline{\text{ERROR}}$	BUSY	$\overline{\text{ACKNLG}}$	SLCT	DATA ENTRY
OFF-LINE	HIGH/LOW	DC 1/DC 3	LOW	HIGH	Not Generated	LOW	Impossible
ON-LINE	HIGH	DC 1	HIGH	LOW/HIGH	Generated	HIGH	Possible (Normal entry)
		DC 3	HIGH	LOW/HIGH	Generated	LOW	Possible (See Note 1.)
	LOW	DC 1/DC 3	HIGH	LOW/HIGH	Generated	HIGH	Possible (Normal entry)

- NOTES: 1. In Table A2-2, it is assumed that as soon as the Printer receives data, it sends back the ACKNLG signal, though this data is not stored in the print buffer. In this status, the Printer is waiting for the DC 1 code for normal entry.
2. In the above table, it is also assumed that no ERROR status exists other than that attributable to the OFF-LINE position of the ON LINE switch. In the ERROR status, the Printer is not in the Selected state (SLCT = "LOW").
3. The DC 1/DC 3 code is valid under the condition that the DIP switch pin 1-8 is OFF, namely, the level of SLCT IN at the pin No. 36 of the interface connector is "HIGH." With SLCT IN at "LOW" level, the Printer is always placed in the Selected state, and the DC 1 /DC 3 code is not valid.
4. When power is applied, if SLCT IN is at "LOW" level or the DIP switch pin 1-8 is OFF, the Printer is regarded as in the Deselected state.

APPENDIX 4 Character Fonts

(Hex Code)

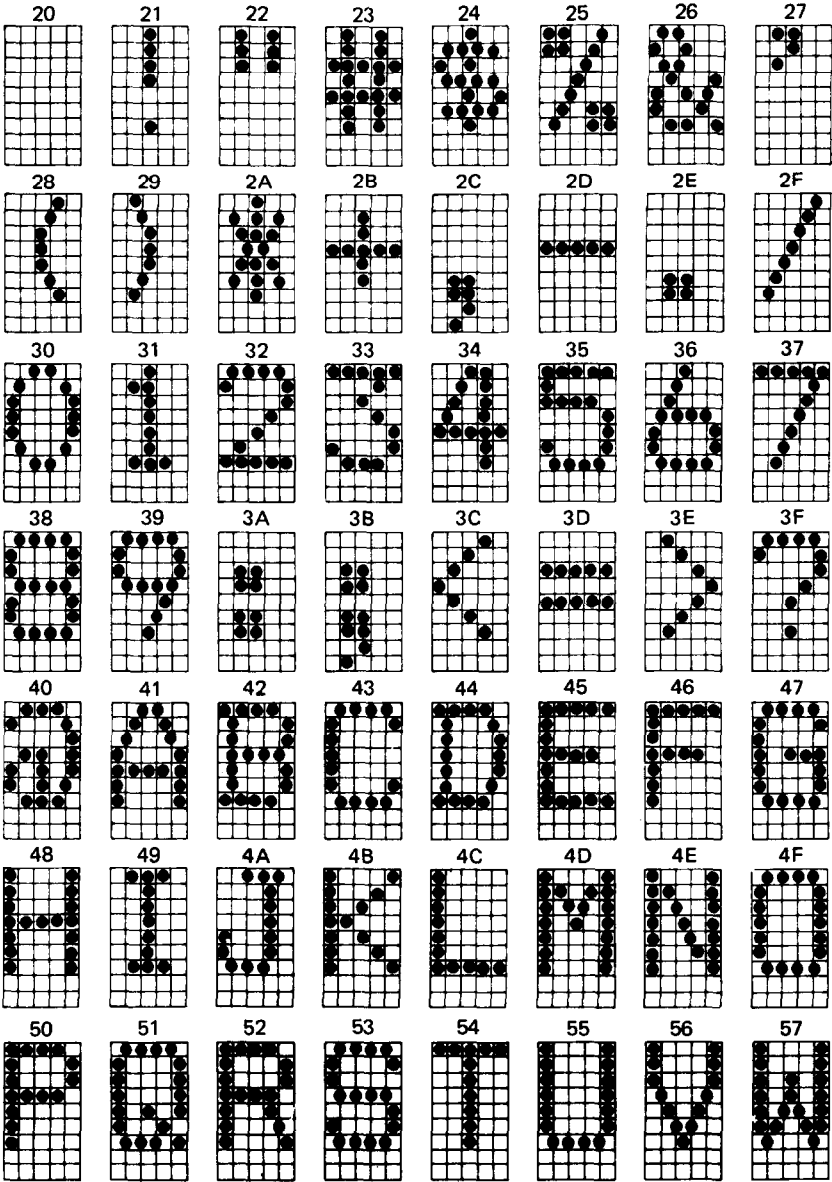

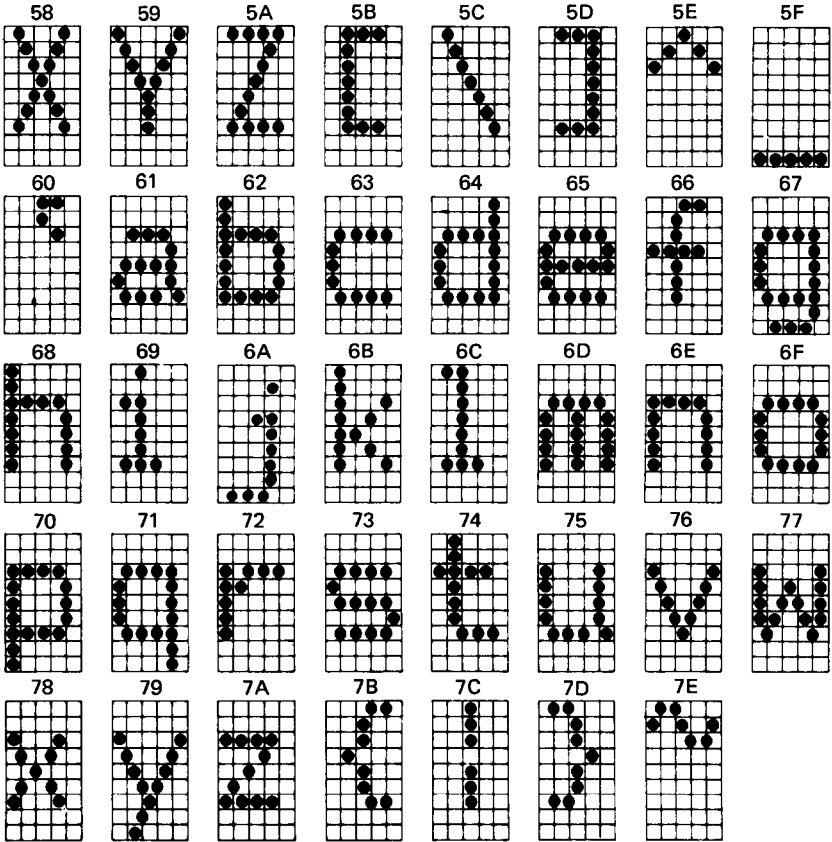

NOTE: Numbers represent Hex. code

FRANCE

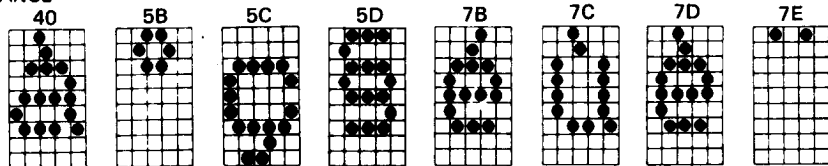

GERMANY

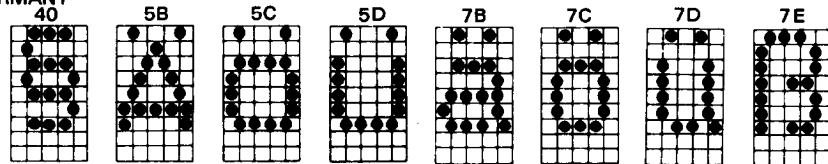

ENGLAND

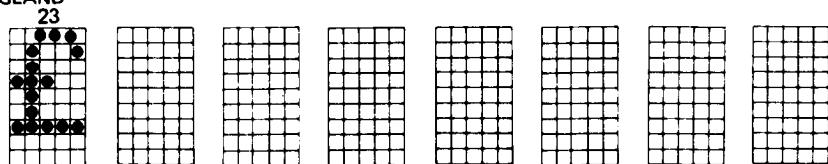

DENMARK

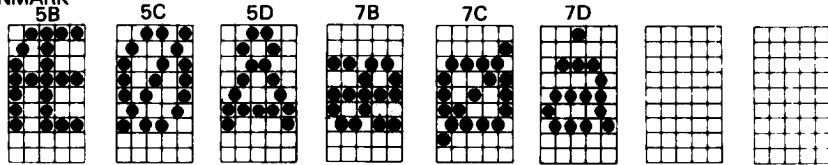

SWEDEN

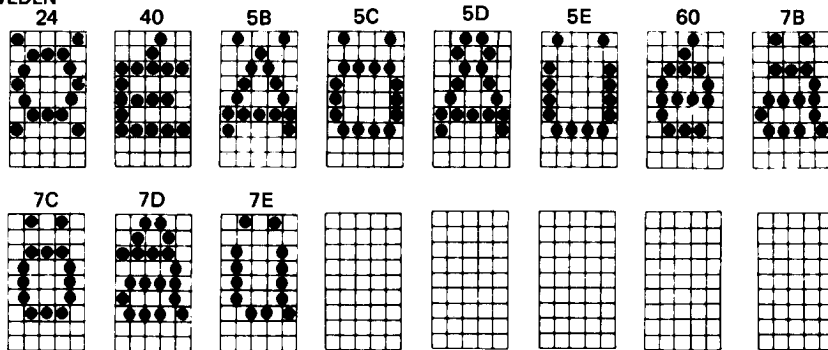

ITALY

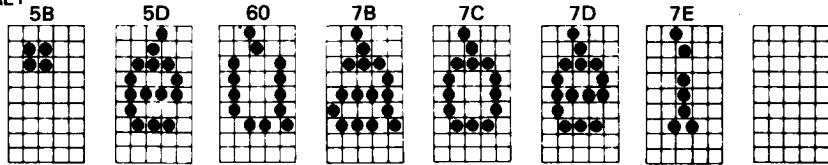

APPENDIX 5 Control Codes

Control code	Hex.	Dec.	Function	Ref. page
NUL	00	0	NULL. Ends tab setting. Follows ESC B and ESC C.	67
BEL	07	7	BELL. Sounds buzzer for about 1 second.	66
BS	08	8	Back space. Cancels a last character input.	66
HT	09	9	Horizontal Tabulation.	58
LF	0A	10	Line Feed.	57
VT	0B	11	Vertical Tabulation.	57
FF	0C	12	Form Feed. Advances paper to next Top of Form.	57
CR	0D	13	Carriage Return.	57
SO	0E	14	Shift Out. Turns on the enlarged character printing mode.	63
SI	0F	15	Shift In. Turns on the condensed character printing mode.	64
DC1	11	17	Device Control 1. Selects printer. Ready to receive data.	66
DC2	12	18	Device Control 2. Turns off the condensed character printing mode.	64
DC3	13	19	Device Control 3. Deselects printer. Not ready to receive data.	66
DC4	14	20	Device Control 4. Turns off the enlarged character printing mode.	64
ESC	1B	27	Escape. ASCII code for Escape. Precedes numbers and alphabets.	55
ESC 0	30	48	Sets a line spacing to 8 lines per inch.	61
ESC 2	32	50	Sets a line spacing to 6 lines per inch.	61
ESC 8	38	56	Deselects paper end detector.	66
ESC 9	39	57	Selects paper end detector.	66
ESC A	41	65	Sets a line spacing between a range from 1/72" to 85/72".	60
ESC B	42	66	Sets VT up to 8 positions.	61
ESC C	43	67	Sets form length up to 127 lines or 22".	62
ESC D	44	68	Sets HT up to 12 positions.	58
ESC E	45	69	Turns on the emphasized character printing mode.	65
ESC F	46	70	Turns off the emphasized character printing mode.	65
ESC K	4B	75	Turns on the normal density bit image mode.	67
ESC L	4C	76	Turns on the dual density bit image mode.	67
ESC N	4E	78	Sets skip-over perforation.	62
ESC O	4F	79	Releases skip-over perforation.	63
ESC Q	51	81	Sets a column length.	59
ESC R	52	82	Selects an international character set from among 8 languages.	65

FEDERAL COMMUNICATIONS COMMISSION
RADIO FREQUENCY INTERFERENCE
STATEMENT

"This equipment generates and uses radio frequency energy and if not installed and used properly, that is, in strict accordance with the manufacturer's instructions, may cause interference to radio and television reception. It has been type tested and found to comply with the limits for a Class B computing device in accordance with the specifications in Subpart J of Part 15 of FCC Rules, which are designed to provide reasonable protection against such interference in a residential installation. However, there is no guarantee that interference will not occur in a particular installation. If this equipment does cause interference to radio or television reception, which can be determined by turning the equipment off and on, the user is encouraged to try to correct the interference by one or more of the following measures:

- reorient the receiving antenna
- relocate the computer with respect to the receiver
- move the computer away from the receiver
- plug the computer into a different outlet so that computer and receiver are on different branch circuits.

If necessary, the user should consult the dealer or an experienced radio/television technician for additional suggestions.

The user may find the following booklet prepared by the Federal Communications Commission helpful: "How to Identify and Resolve Radio-TV Interference Problems."

This booklet is available from the US Government Printing Office, Washington, D.C., 20402, Stock No. 004-000-00345-4."

This statement will be applied only for the printers marketed in the U.S.A.

EPSON

SHINSHU SEIKI CO., LTD.

EPSON OVERSEAS MARKETING LOCATIONS

EPSON AMERICA, INC. (L.A.)
3415 Kashiwa St.
Torrance, Calif., 90505
Phone: (213) 539-9140
Telex: (230) 182412

EPSON AMERICA, INC. (N.Y.)
98 Cutter Mill Road
Great Neck, New York, 11021
Phone: (516) 487-0660
Telex: (25) 510223-0743

EPSON DEUTSCHLAND GMBH
Am Seestern 24
4000 . Düsseldorf 11
F.R. Germany
Phone: (0211) 596-1001
Telex: (41) 8584786

EPSON U.K. LTD.
Sherwood House 176 Northolt Road
South Harrow
HA2 OEB U.K.
Phone: (01) 422-5612, (01) 422-1 118
Telex: (51) 8814169
